



Little Crow

Solar Park

Little Crow Solar Park, Scunthorpe

ENVIRONMENTAL STATEMENT: TECHNICAL APPENDICES

APPENDIX 3.1

FLOOD RISK ASSESSMENT AND DRAINAGE STRATEGY

Revision:
APFP Reg:
PINS Reference:

Submission
5(2)(e)
EN010101

Author:
Date:

Clive Onions
November 2020

INRG Solar (Little Crow) Ltd

Little Crow Solar Park, Scunthorpe DN20 0BG

Flood Risk Assessment and Drainage Strategy

20th November 2020

V14

This report is based on the instructions given by our client. It is not intended for use by a third party, and no responsibility will be given to any third party.

The consultant has followed accepted procedure in providing the services, but given the residual risk associated with any prediction and the variability which can be experienced in flood conditions, the consultant takes no liability for and gives no warranty against actual flooding of any property (client's or third party) or the consequences of flooding in relation to the performance of the services.

Clive Onions Director
BSc CEng FICE FCIWEM
MIStructE MCIHT

Clive Onions Ltd
2 Stowey Cottages
Golds Cross
Pensford
Bristol BS39 4DL

t 01275 332 216
m 07836 268 939
e info@cliveonions.com
www.cliveonions.com

Company registered in
England and Wales number:
7444467

Registered office: Unit 4b,
Winford Business Park,
Winford, Bristol BS40 8JH

Contents

- 1 Summary of Key Issues
- 2 Introduction
- 3 Order Limits Location and Setting
- 4 Existing Order Limits and Ground Conditions
- 5 Proposed Development
- 6 Hydrology and Flood Risk
- 7 Surface Water Drainage
- 8 Construction Process
- 9 Land Drainage Consent
- 10 Management and Maintenance
- 11 Conclusions and Recommendations

Appendix

- 1 Completed Land Drainage Consent Form and Plans followed by the Formal Consent
- 2 Environment Agency Response to Consultation
- 3 Pre-application Consultation Response with Comment from Drainage Officer
- 4 Shires Group Response to Consultation acting for Internal Drainage Board

Glossary

Reference List

Report prepared by Sam Rice – BSc (Hons)

Report approved by Clive Onions – BSc CEng FICE FCIWEM MStructE MCIHT

Version history

Version	Date	Prepared by	Approved by	Comment
V1	20.07.18	CO	CO	Final layout inserted
V2	26.07.18	CO	CO	Minor amendments
V3	16.11.18	SR	LJ	Updated with revised layout
V4	19.11.18	SR	CO	Updated area of development
V5	12.08.19	CO	CO	Updated report and added Land Drainage Consent Forms
V-6	24.10.19	LJ	CO	Format changed and plan of 23.10.19 inserted
V7	27.11.19	LJ	CO	Plan of 21.11.19 inserted
V8	28.11.19	LJ	CO	Revised Fig 18
V9	23.07.20	LJ	CO	Revised boundary
V10	04.08.20	LJ	CO	Revised plans
V11	18.10.20	CO	CO	Revise Plans & terminology
V12	20.10.20	CO	CO	Minor amendments
V13	20.10.20	CO	CO	Minor amendments
V14	20.11.20	LJ	CO	Revised plans

Issue history

Version	Date	Issued to	Method
V1	20.07.18	Pegasus Group, INRG	Ditto
V2	26.07.18	Ditto	Ditto
V3	16.11.18	Ditto	Ditto
V4	19.11.18	Ditto	Ditto
V5	12.08.19	Ditto	Ditto
V-6	24.10.19	Ditto	Ditto
V7	27.11.19	Ditto	Ditto
V8	28.11.19	Ditto	Ditto
V9	23.07.20	Ditto	Ditto
V10	04.08.20	Ditto	Ditto
V11	18.10.20	Ditto	Ditto
V12	20.10.20	Ditto	Ditto
V13	20.10.20	Ditto	Ditto
V14	20.11.20	Ditto	Ditto

1. Summary of Key Issues

In summary:

- The Order Limits is entirely in Flood Zone 1 according to the EA Flood Map for Planning and development is appropriate in this area in terms of fluvial flood risk.
- The local area to the Order Limits is not sensitive in terms of surface water flood risk.
- The Order Limits is currently used for arable farming which causes compaction, reduces absorption of rainwater by the soil and increases soil and silt runoff, particularly after harvesting.
- The natural soil within the Order Limits is recorded as being free-draining.
- The hydrological assessment takes into consideration the Government's latest Climate Change Allowances, dated 22nd July 2020.
- Swales are proposed to reduce the risk of runoff and silt affecting the watercourse flows, especially during the construction phase.
- A swale is also proposed uphill of the poultry farm in the northeast of the Order Limits, to reduce the risk of runoff affecting the farm, especially during construction phase.
- The proposal will eliminate compaction, allow the soil and vegetation properties to improve and manage rainfall naturally within the Order Limits, by infiltration into the ground.
- Tracks will be formed in permeable construction to drain by infiltration.
- Track crossings of watercourses will incorporate large diameter culverts to reduce the risk of blockage.
- A Land Drainage Consent form for the crossings has been submitted and the Land Drainage Consent has been granted by the Lead Local Flood Authority.
- Transformer and Battery Energy Storage System foundations will be formed with permeable gravel beds to drain rainfall by infiltration.
- A management programme is described which ensures the soil and watercourse conditions will remain favourable for the lifetime of the development.
- The proposal brings significant benefit to the management of surface water, a reduction in runoff leaving the Order Limits and the improvement in water quality entering the environment.
- Runoff quality entering the environment will improve through ceasing the application of pesticides and fertilizers.

- The development reduces the risk of flooding to the local area or lower in the catchment.
- The Environment Agency, the Internal Drainage Board and North Lincolnshire Council (as Lead Local Flood Authority) have been consulted and there are no objections to the proposals.
- A Land Drainage Consent form has been submitted to North Lincolnshire Council in their capacity as Lead Local Flood Authority and Land Drainage Consent has been granted.
- The proposals comply with the National Planning Policy Framework (NPPF) and are therefore acceptable.

2. Introduction

INRG Solar (Little Crow) Ltd proposes the construction, operation, maintenance and decommissioning of a ground mounted solar park and associated Battery Energy Storage System with an intended design capacity of over 50MWp (megawatts peak) on land to the east of the British Steel site at Scunthorpe. The operational lifespan will be 35 years.

This Flood Risk Assessment and Drainage Strategy (FRADS) has been prepared to consider the impact of the solar park on the existing hydrology in the area, to show that flood risk is not increased off-site of the Order Limits and that the solar park is safe to operate for its lifetime. It considers the construction and operation stages.

The assessment shows that water quality entering the environment will be improved, infiltration will improve and runoff rates will be reduced, bringing overall benefit to the environment.

The Order Limits and general area was inspected by Clive Onions on 20th August 2019 on a damp day following heavy rain the previous day.

3. Order Limits Location and Setting

The Order Limits is located on land to the east of British Steel, Scunthorpe DN20 0BG.

The Order Limits is in the following setting:

- North of the Order Limits is Santon Wood, beyond which is mainly arable farmland, on land generally falling to the west.

- East of the Order Limits is woodland, a poultry farm and the town of Broughton on land falling gently to the east.
- South of the Order Limits is strip of woodland, beyond which is arable farmland, a solar park, covered reservoirs, a golf course, further woodland, etc., on land which falls to the west.
- West of the Order Limits is a deep ditch (approx. 3m deep), an access track and a narrow strip of green land containing a small arable field, beyond which is a deep excavation resulting from open cast mining, containing standing water some 20m below the level at the Order Limits boundary. Beyond this is Bottlesford Beck, at similar level to the Order Limits site boundary, which drains the adjacent British Steel works and industrial estate.

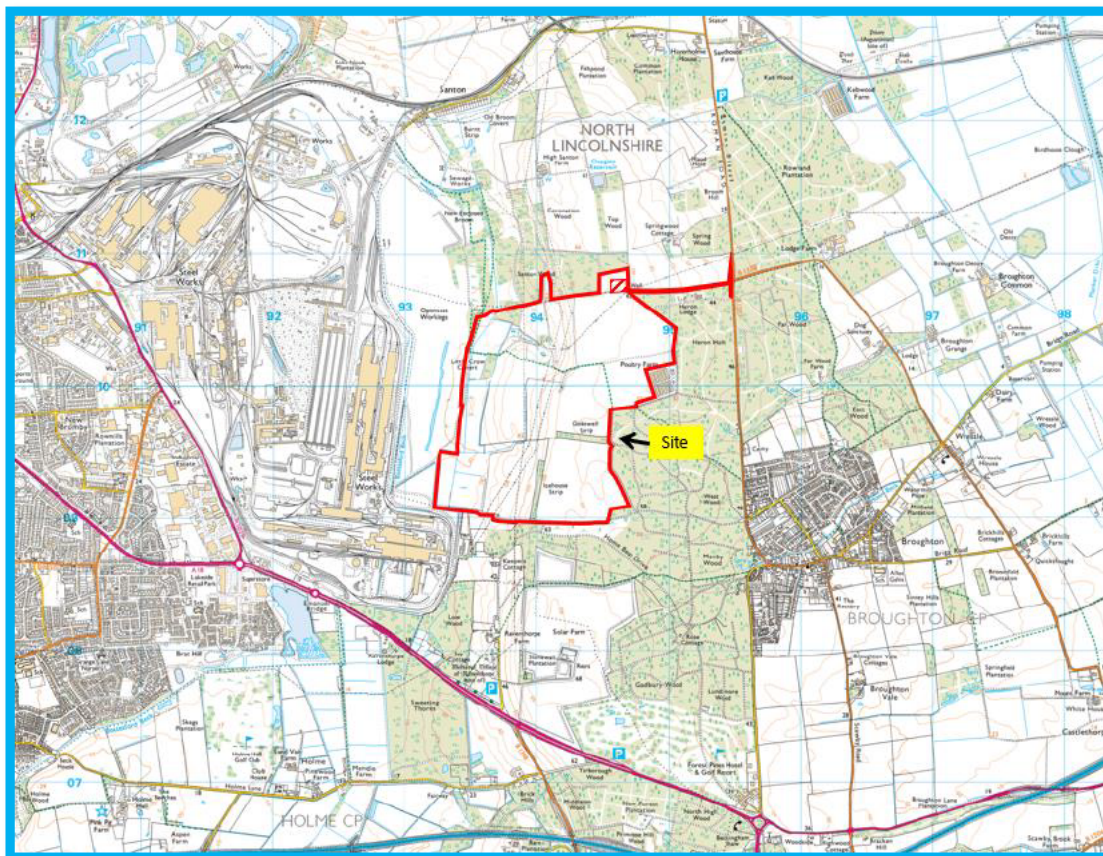

Fig 1 Location map showing the Order Limits to the east of Scunthorpe (Streetmap).

In summary, Little Crow Solar Park is proposed on arable farmland, sheltered by woodland to the north, east and south, with an important industrial area (British Steel), to the west.



Fig 2 Oblique view of land between the industrial land (British Steel) and the Order Limits, showing the 20m (approx.) deep excavation and standing water (Google Earth image by Getmapping plc).

4. Existing Order Limits and Ground Conditions

The Order Limits occupies approx. 20 fields separated by hedgerows with occasional trees and fences. The fields are predominantly used for arable farming.

The shape of the Order Limits is irregular and is approx. 1,850m north-south and 1,550m east-west, with an area of about 225ha. There are no buildings shown within the Order Limits, although pylons carrying two main overhead electrical circuits cross north-south through the Order Limits site.

The Order Limits includes watercourses which are described later, but tend to flow south-westwards from a spring line which runs along the north-south axis of the Order Limits, following approximately the line of overhead pylons.

The Order Limits slopes from approximately 60m AOD in the east to 25m AOD in the west, giving an average slope of about 1 in 25. The northwestern part of the Order Limits is generally level at about 60m AOD, with a gentle 1 in 100 slope to 55m AOD along the north-eastern boundary.



Fig 3 Satellite view showing Order Limits in predominantly arable use within the Order Limits site (Indicative Aerial image of Order Limits Document Ref 2.38 LC DRW). (Background Google Earth image by Getmapping plc).

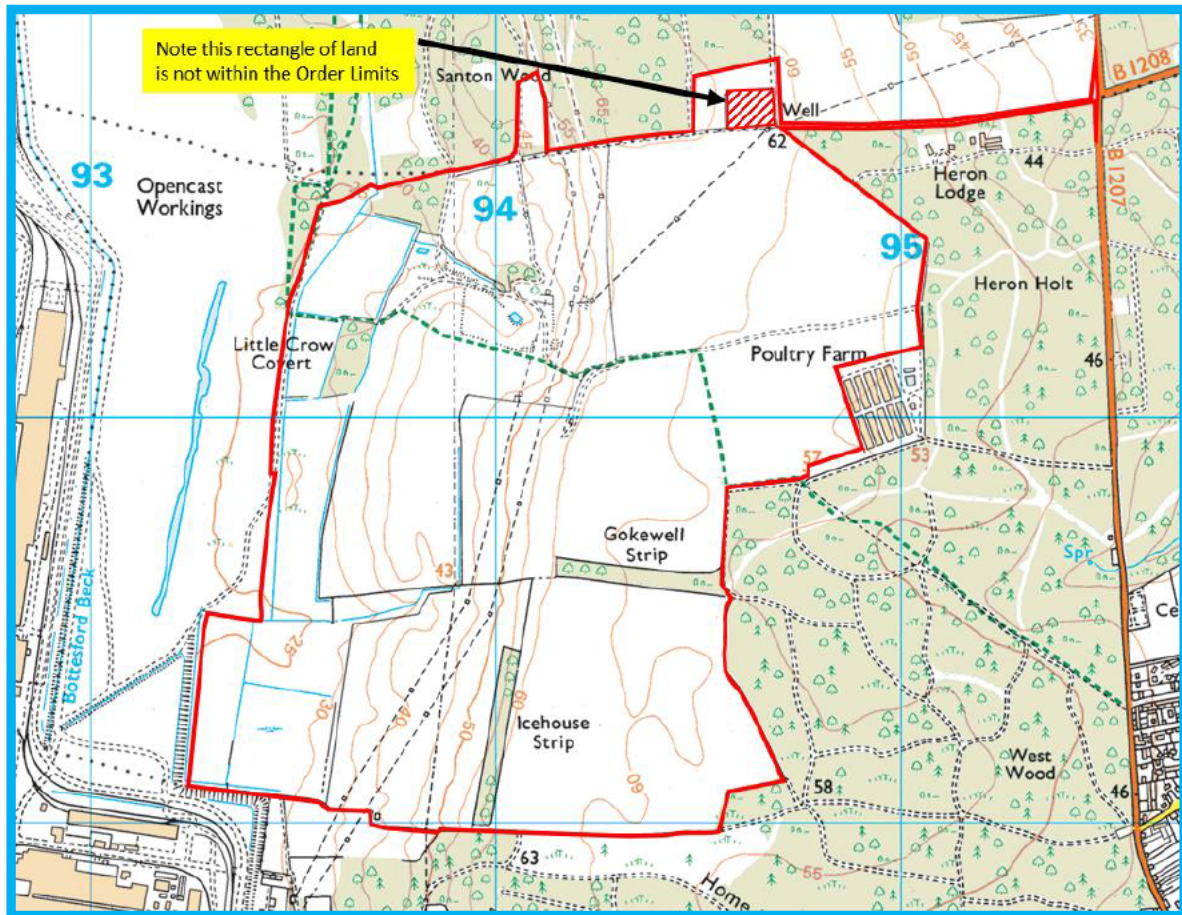

Fig 4 More detailed view of Order Limits site showing the British Steel works to the west, Bottesford Beck, low-level opencast workings area and then the Order Limits, with an oil well to the northeast and a poultry farm to the east. Within the Order Limits are the power lines running north-south and the watercourses flowing south-westwards from the spring line (Streetmap).

A separate geotechnical report (Document 7.5 LC TA 3.3) has been prepared by Integrale Ltd, Geotechnical Consultants, but in summary the British Geological Survey Viewer shows sand above mudstone in the west and mudstone and limestone in the east. The Cranfield University Soilscales Viewer shows the soil within the Order Limits to be free draining. This assessment suggests that the Order Limits surface is likely to be permeable, with limited runoff from rainfall.

At the site inspection there was no evidence of runoff from the fields, and the surface gave the appearance of being free draining.



Fig 5 Image at northwest of Order Limits showing land falling towards the track and no sign of streaming within the field, yet ponding on the compacted gravel track. Photograph taken 20th August 2019 following heavy rain the previous day.

However, in extreme events, in autumn and winter, runoff carrying silt will occur after ploughing, and before the vegetation/crops have become established. The runoff would diminish as the vegetation begins to flourish in the growing season leading to variations of flow in the receiving watercourses and potentially increasing the risk of silting in the watercourses.

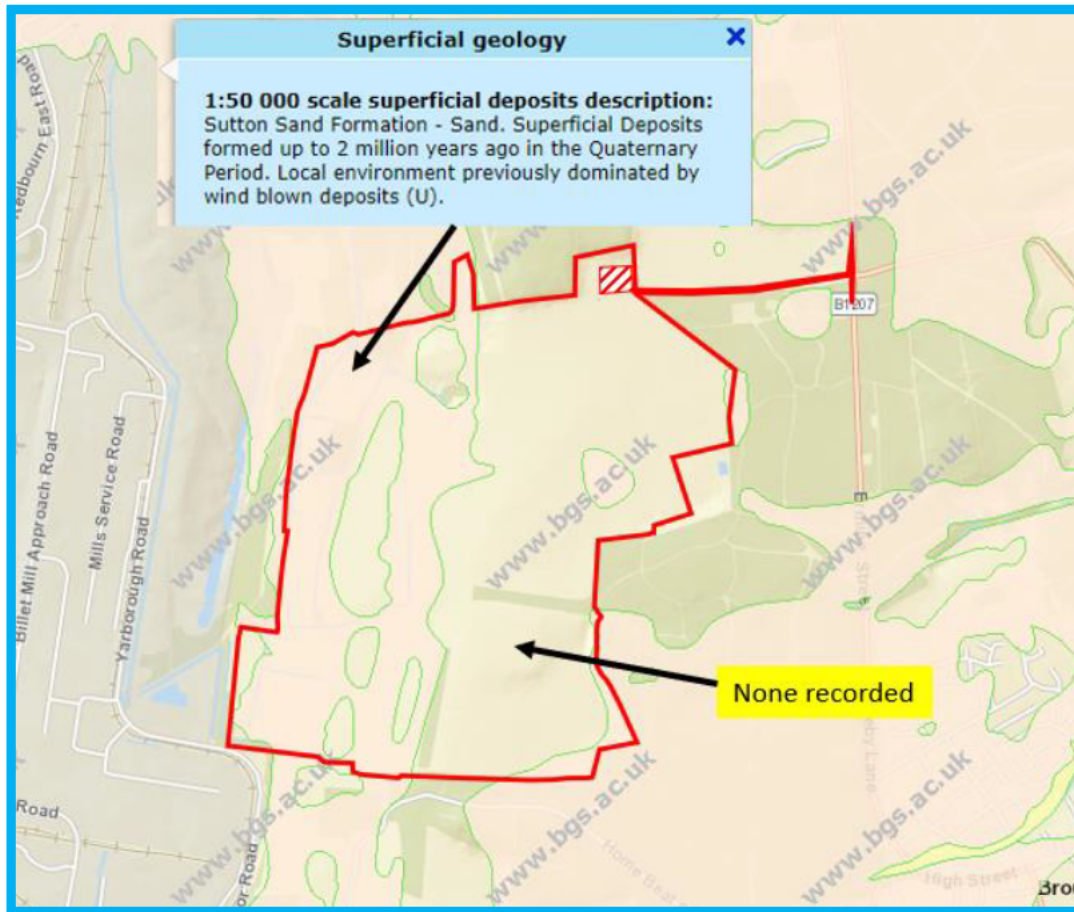

Fig 6 The superficial geology, noting Sutton Sand in the west and none recorded in the east (British Geological Survey).

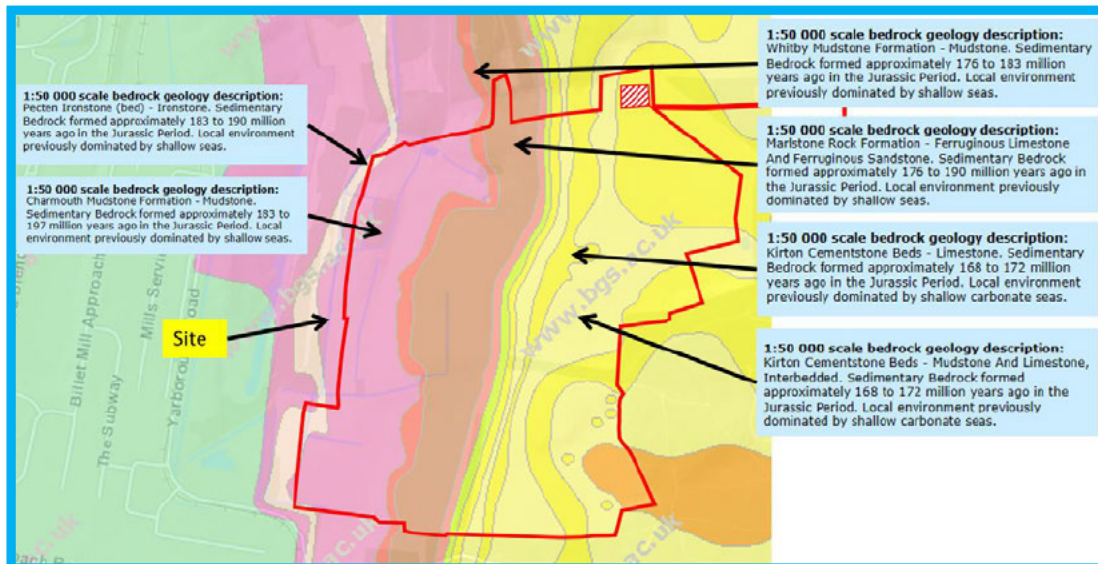

Fig 7 The bedrock geology, showing the variety of permeable limestones on the higher (eastern) ground and less permeable mudstones on the lower (western) ground (British Geological Survey).

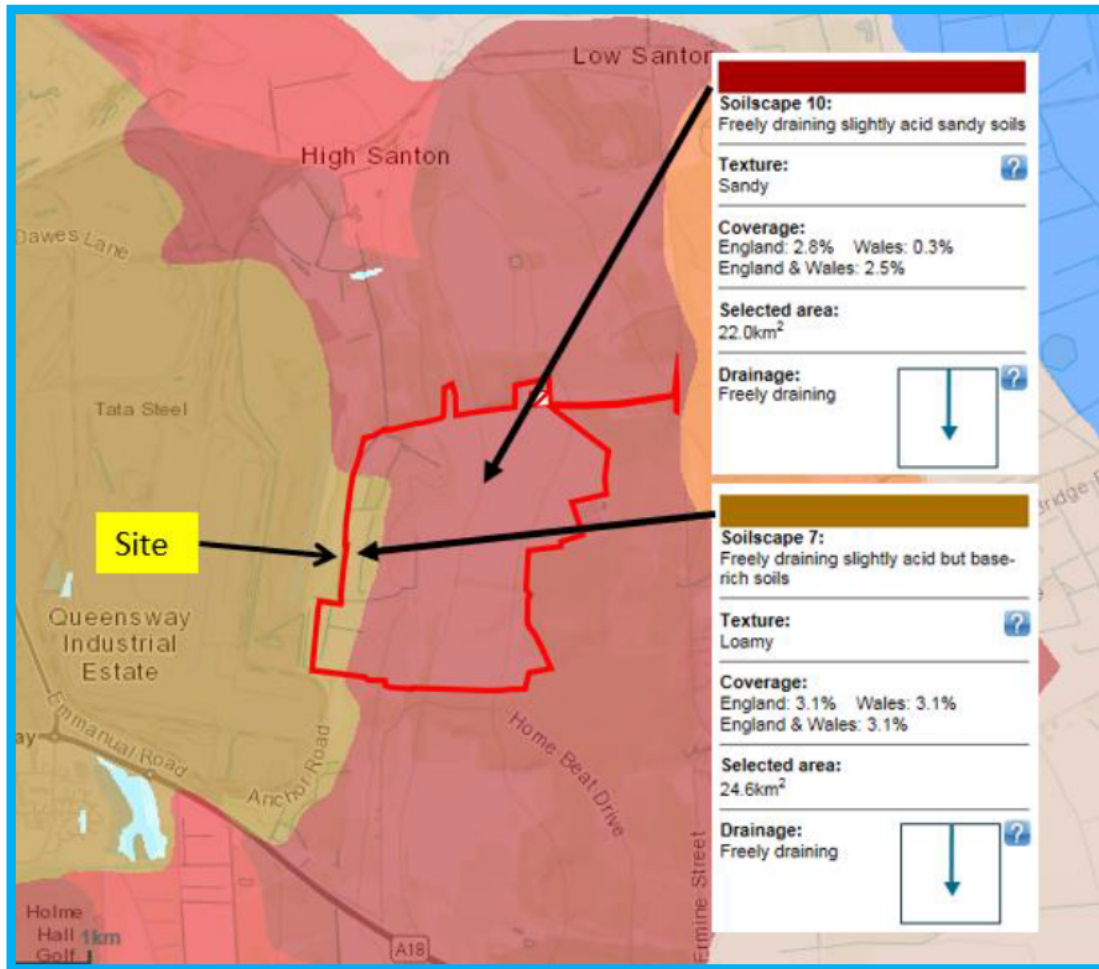

Fig 8 Soilscape Viewer showing the soil throughout the Order Limits to be free-draining (Cranfield University Soilscape Viewer).

5. Proposed Development

The proposal is the construction, operation, maintenance and decommissioning of a ground mounted solar park and associated Battery Energy Storage System with an intended design capacity of over 50MWp (megawatts peak) on land to the east of the British Steel site at Scunthorpe. Little Crow Solar Park also includes transformers and cables within the Order Limits to manage and convey the power.

The arrays of solar panels will be aligned east-west, to collect sun from the south, with the lowest edge 700mm off the ground, and the highest (northern) edge up to 3.5m off the ground; the dimensions will vary with the local topography. The solar panels incorporate joints along the array, and several joints up the slope, which are fundamental for thermal movement. These joints encourage rainwater to disperse along the array and avoid concentrated drips from the lower edge.

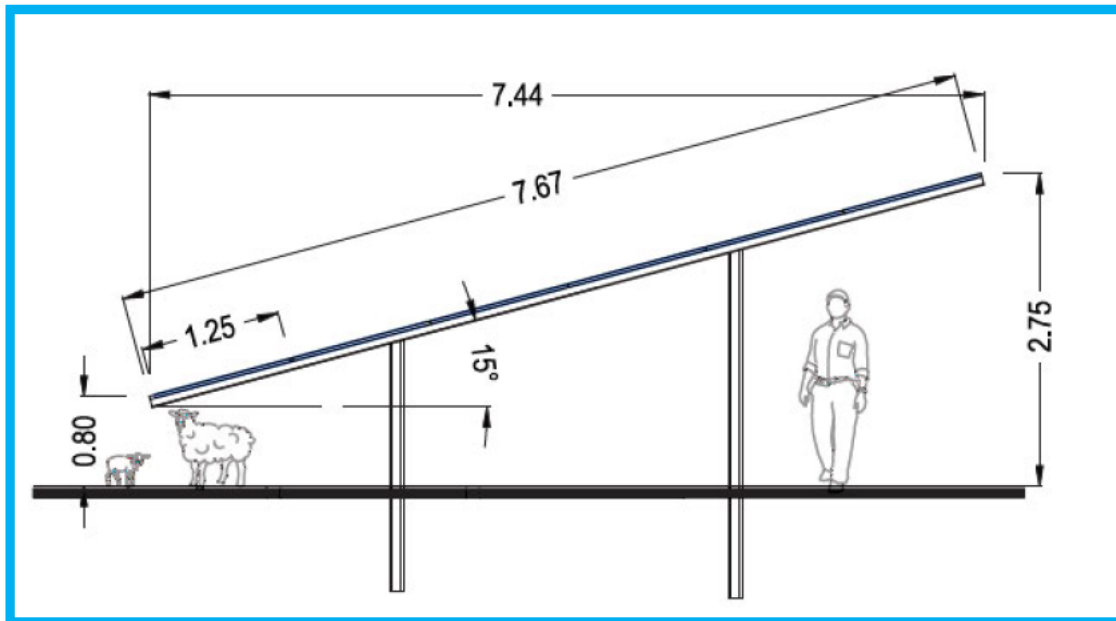

Fig 9 Typical section through array. Height dimensions will vary with undulations in the ground.

The arrays are positioned approximately 3m apart to provide access space between the solar panels and to reduce shadowing. Generally, the fence will be up to 10m from the perimeter hedge, and a further 3.5m from the fence to the nearest array. These dimensions allow access for maintenance of the hedge outside the fence and camera surveillance within the fence.

The solar park will be protected by deer fences, with open mesh and set 100mm above the ground to allow movement of small wildlife and surface water. The fences will cross watercourses in such a way as to reduce the risk of blockage, spanning the channel.

The Main Access Track (Work No. 5) will be upgraded from an unnamed existing track to the northeast of the Order Limits, which connects to the B1207 immediately south of its junction with the B1208.



Fig 10 Existing track from B1207 leading to the north of the Order Limits.

The track which runs into the solar park will be retained and improved as necessary to manage the proposed vehicles. New tracks to key equipment within the Order Limits will be formed in permeable material; the tracks tend to green over due to low usage which helps manage runoff and provides further varied habitat.

The new track network will cross 2 ditches, and a previously planned 3rd ditch crossing is also shown below. The detailed topographic survey shows Location 1 (no longer required) is an existing culverted ditch, Location 2 is a new crossing of a ditch within an overgrown hedge and Location 3 is an existing farm crossing. Details are provided in Appendix 1, which includes the completed Land Drainage Consent form submitted to the Lead Local Flood Authority (LLFA) for all 3 crossings (prior to abandoning crossing 1), followed by their Formal Consent (LLFA Ordinary Watercourse Consent).

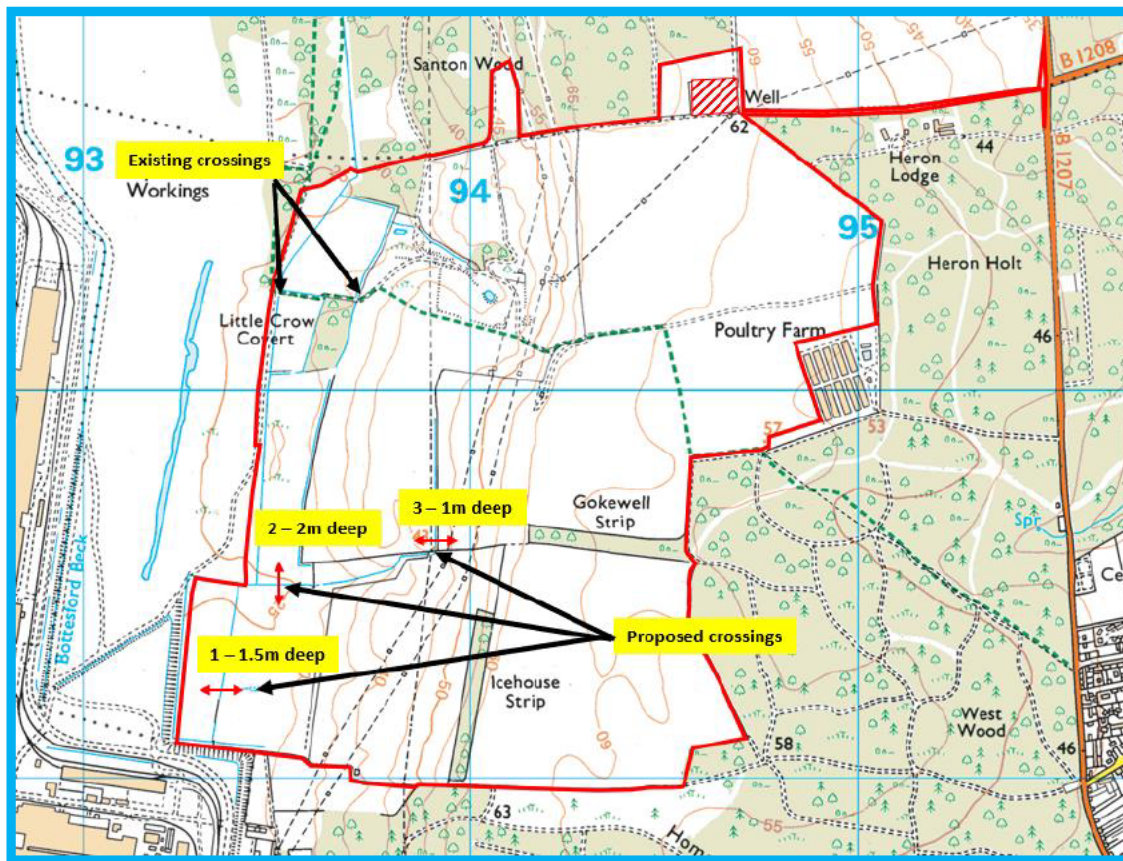

Fig 11 Track crossings labelled 1 (no longer required), 2 and 3, with the depths of the ditches crossed. See Appendix 1 for details.

Cables will be installed across ditches using no-dig techniques and 1m below the bed of the ditches.

The fields on which the solar panels are located will be prepared on completion of the works. This will loosen compacted ground, which will then be seeded where necessary to encourage a vegetated surface throughout with native grasses, and vegetation restored where construction has caused damage. The area within the fence will become a haven for invertebrates, reptiles, amphibians, small mammals and birds, as has been observed on other completed solar park sites.

All the equipment is inert and will not cause pollution during the lifetime of the project.

The vegetation will be maintained, and tall plants trimmed to avoid the solar panels being shaded. Bare areas of earth will be prepared, seeded and protected to encourage vegetation to flourish.

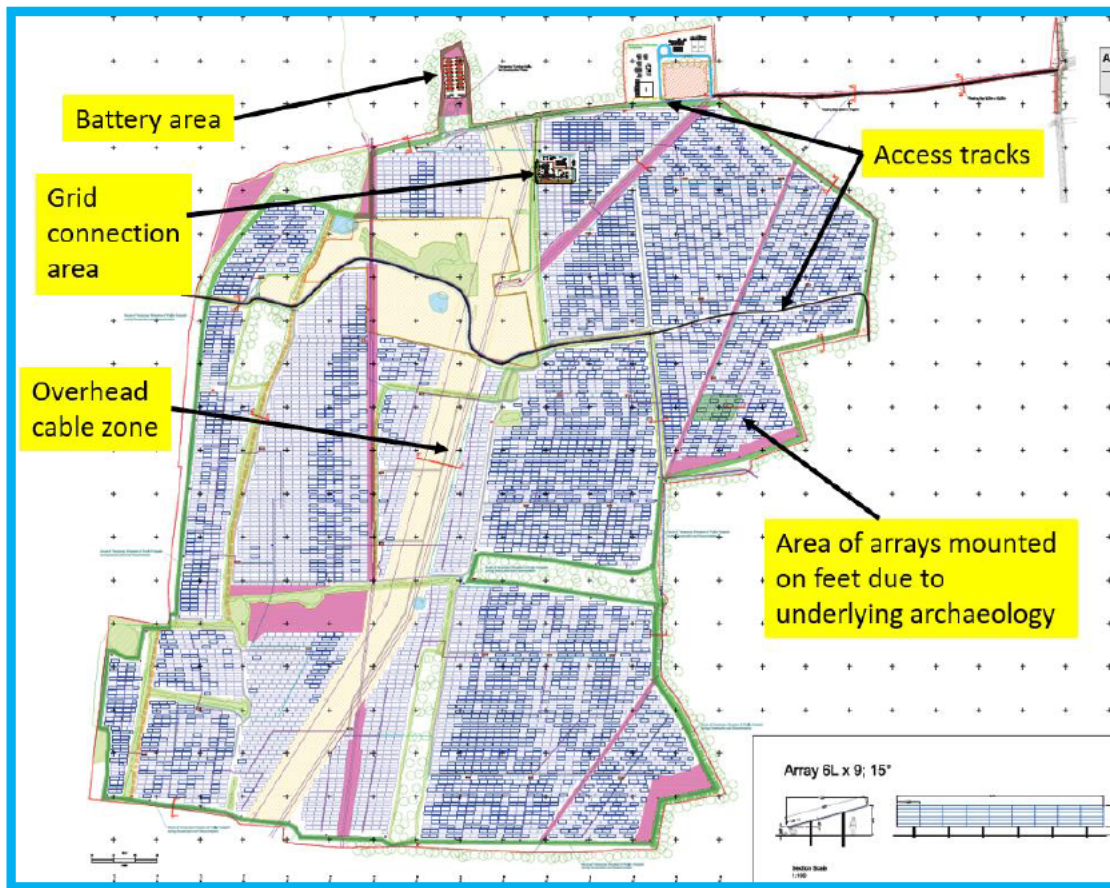

Fig 12a Extract from Works Details – Whole Site Plan (Document Ref 2.10 LC DRW). Note location of Battery Energy Storage System Works No. 2A to the north of the Order Limits.

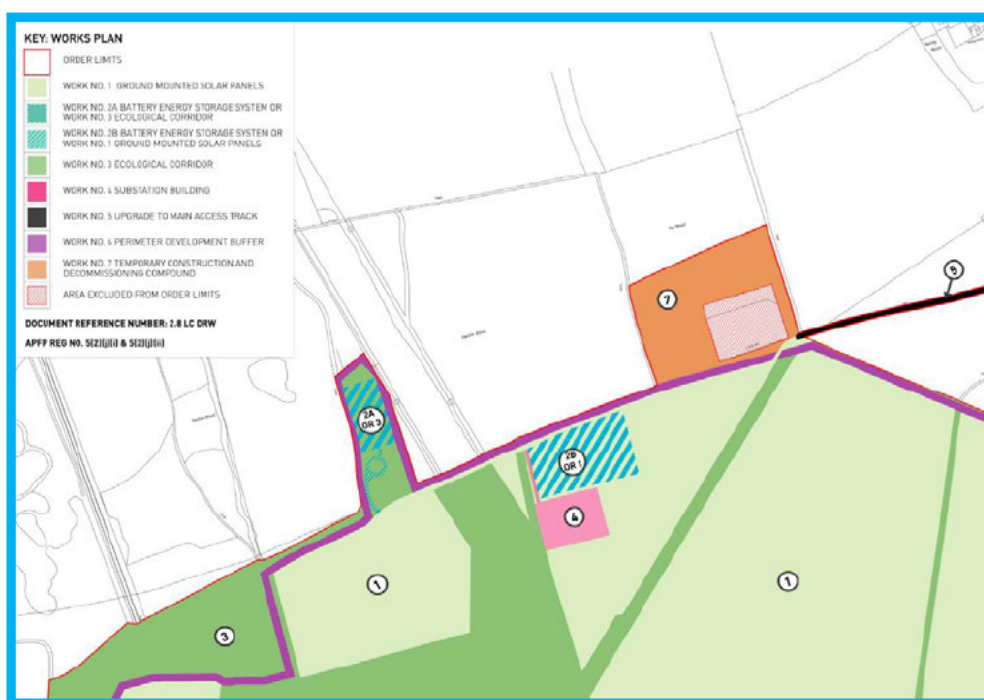

Fig 12b Extract from northern part of Works Plan (Document Ref 2.8 LC DRW), with Key showing Battery Energy Storage System Works No. 2A and 2B (alternative location).

An archaeological no-dig zone is located in the eastern side of the Order Limits. The solar panels in this area will be stabilised by concrete pads, to avoid drilling into the ground. The pads will be 0.75m square and 0.75m x 1.6m, as indicated in the images below. These are in an area which falls towards the poultry farm, some 240m to the east. Given the nature of the permeable soil, the shallow fall of the land, and the fact that the pads are below the solar panels, the area of soil covered by the pads is not anticipated to increase runoff. However, a precautionary swale is proposed along the boundary with the poultry farm which will intercept natural runoff to enhance its infiltration and provide a cut-off feature.

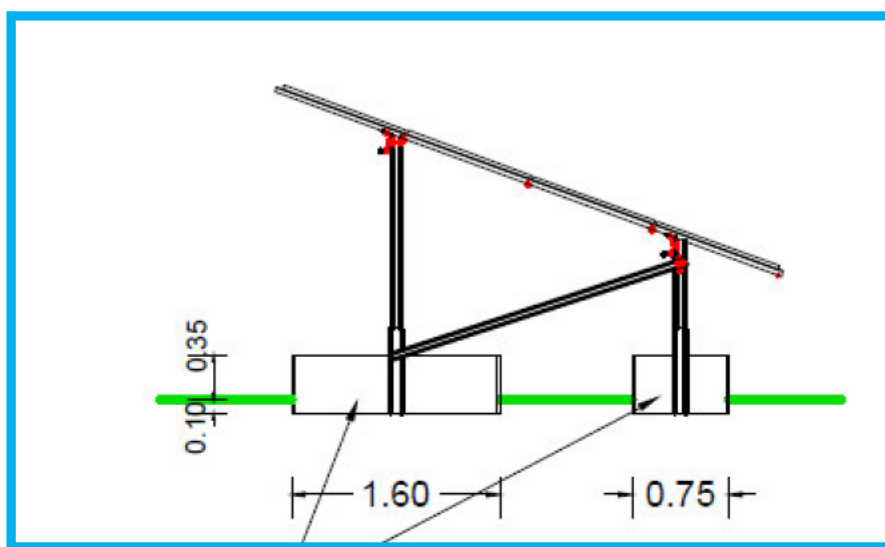

Fig 13 Cross section through array in the archaeological no-dig zone showing concrete pads.

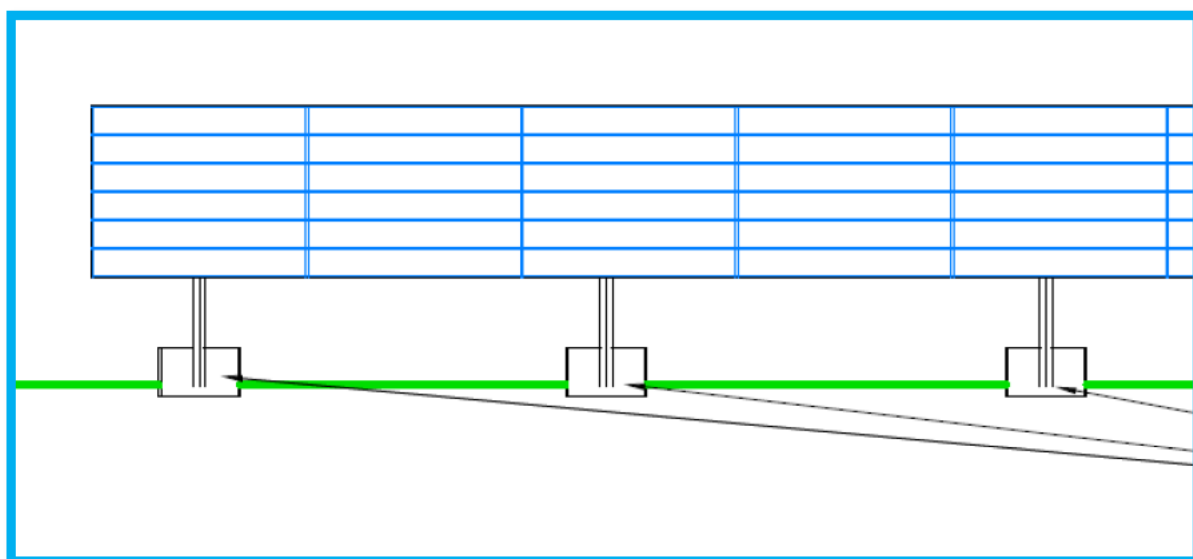

Fig 14 Elevation of array in green archaeological area showing minimal impact of pads on permeable soil.

6. Hydrology and Flood Risk

The Order Limits is located in Flood Zone 1, at low risk of flooding, according to the Environment Agency (EA) Flood Map for Planning, consistent with its elevated location, and the solar park is therefore appropriate development in terms of fluvial flood risk in accordance with the National Planning Policy Framework (NPPF).

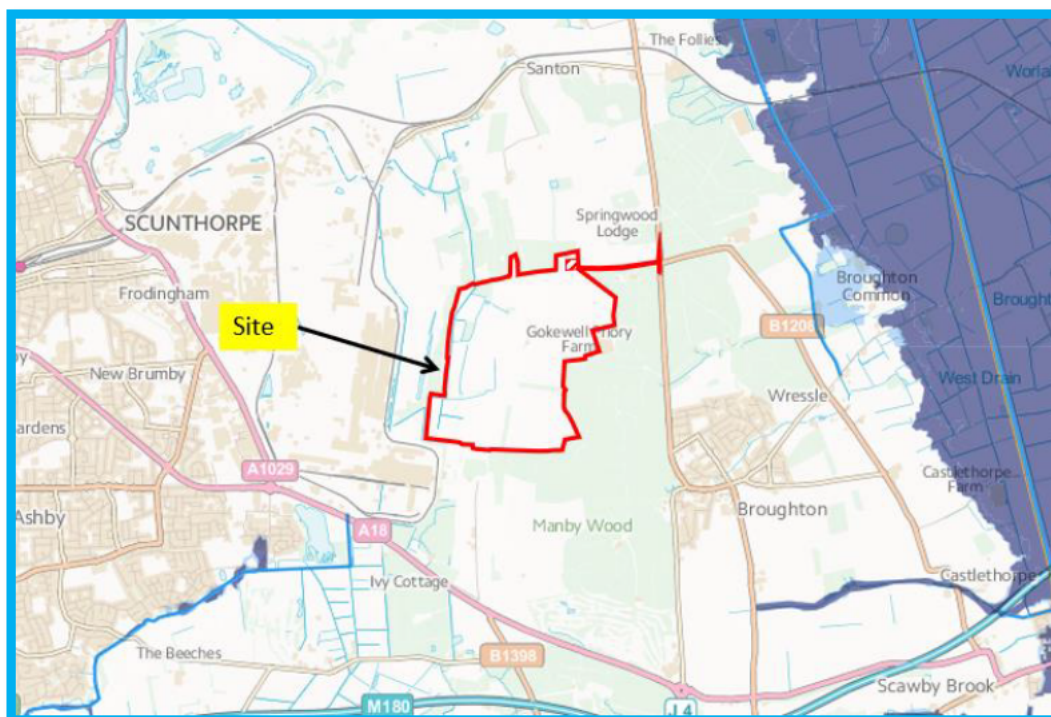

Fig 15 The EA Flood Risk Map for Planning showing the Order Limits to be in Flood Zone 1.

The EA Surface Water Flood Risk Map shows isolated small ponding within the Order Limits – indicative of the sloping land and generally free-draining nature of the soil. In the west of the Order Limits the water is shown to issue from a spring line and flows south-westwards within channels. The spring line is shown below, in an image which has been extracted from the Geotechnical Report.

The Order Limits contains a number of ditches/watercourses, generally running from north to south along the slope, and linked by watercourses flowing westwards down the slope, which are shown on the Ordnance Survey maps. A detailed topographic survey has been undertaken of the Work site and shows that the channels are well-defined and vary from 1m – 2m deep, which was confirmed during the site inspection. There was no water recorded in the ditches at the time of the survey (August 2017).

A streaming area in the northwest is within an open area allocated for ecological/habitat purposes (Extended Phase 1, Arable Plants, Great Crested Newts & Water Vole 7.22 LC TA7.1)

The north-eastern area tends to have a very gentle fall to the east, leading into the woodland. There are no evident watercourses or signs of surface water flows to the east, indicating that the rainfall infiltrates into the ground where it lands, ie the shallow gradient and nature of the soil encourages infiltration.

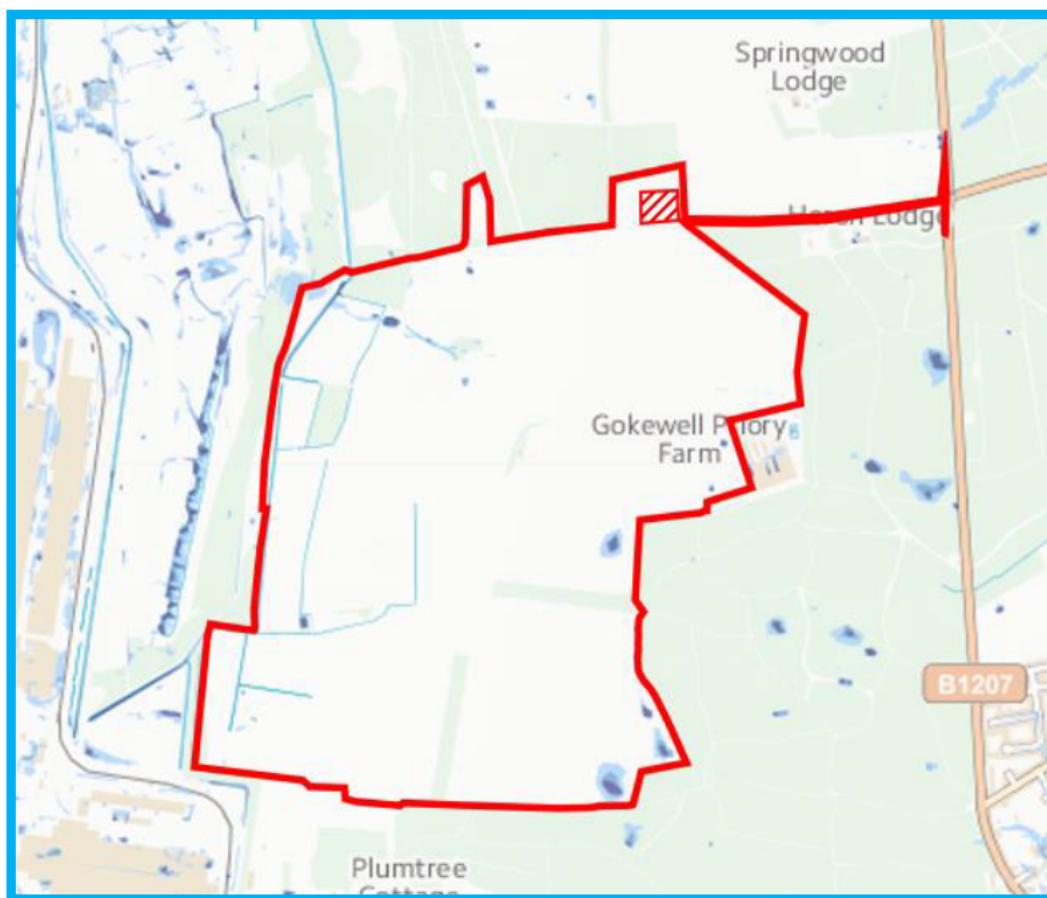

Fig 16 Extract from the EA Surface Water Flood Risk Map showing isolated areas of the Order Limits at risk from surface water ponding in the 1 in 1000 year event (Low Risk Scenario), and an area of shallow streaming in the northwest.

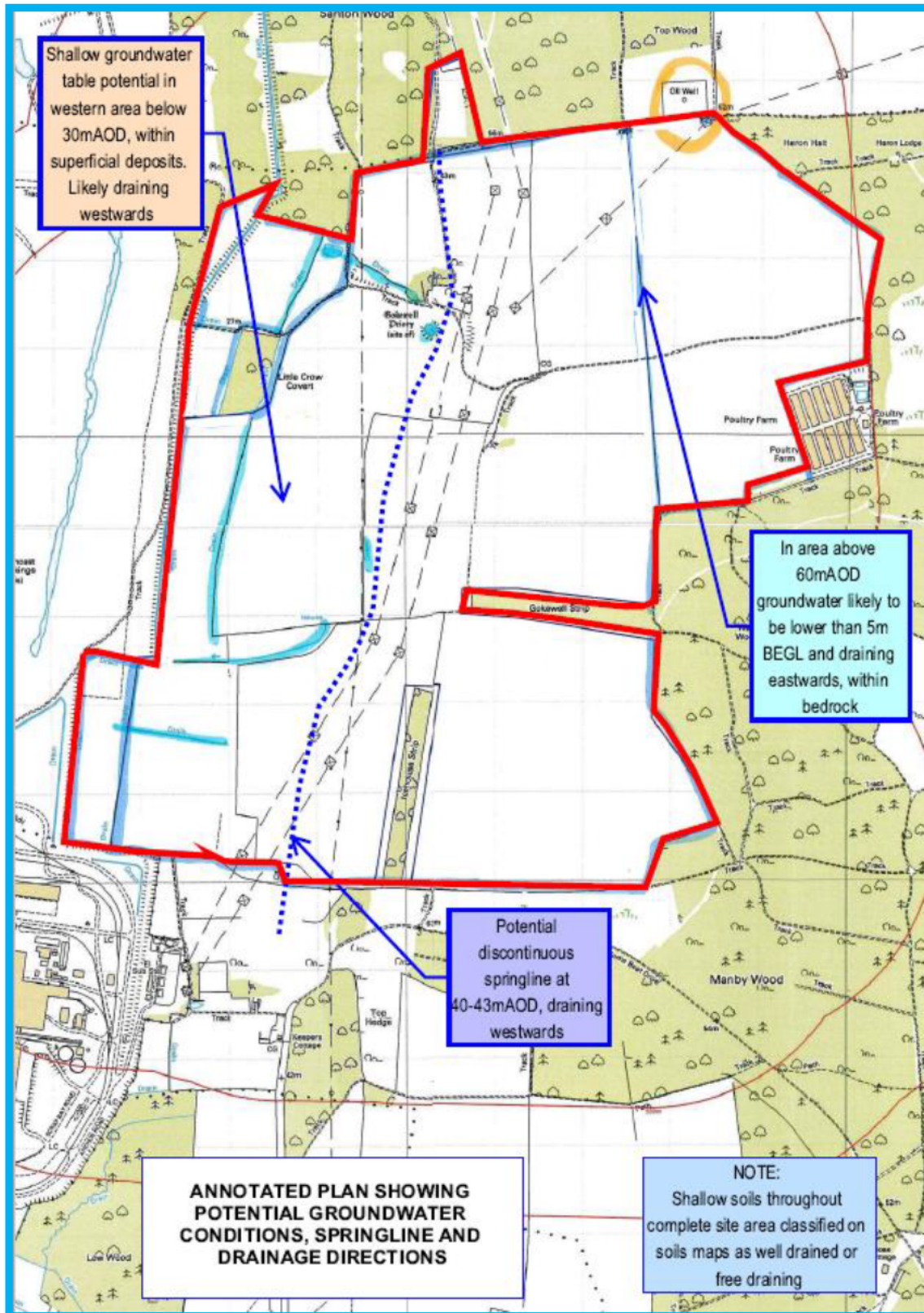

Fig 17 Extract from Integrale’s Phase 1 Ground Conditions Desk Study (Document 7.4 LC TA 3.2) showing the spring line and proposed Battery Energy Storage System Works No. 2A to the east (uphill) of the spring line. (The red outline is indicative of the study area used for Integrale’s report and does not represent the Order Limits).

7. Surface Water Drainage

The soil is shown to be free-draining on the EA maps, which has been confirmed by site inspection. The underlying soil is naturally drained by the springs which issue along the spring line. The mechanism would therefore be that rainfall infiltrates into the soil, and then follows a layer with low permeability and issues from the ground at a generally low rate over a prolonged period, forming a watercourse in a ditch. It is proposed to retain all the watercourses and provide a minimum 6m buffer from top of bank with no development.

This assessment takes into account the latest Government Climate Change Allowances dated 22nd July 2020.

The boundary fences will cross the watercourses 100mm above top of bank level, thus avoiding risk of blockage.

Swales will be formed on the uphill side of the main watercourses as a precautionary measure to manage runoff and silt during the construction period.

A swale is also proposed along the west and north of the poultry farm to reduce the risk of runoff nuisance.

The swales will be formed by excavating a 300mm deep valley and placing the soil on the downhill slope, and about 3m wide – using the ridge and furrow technique.

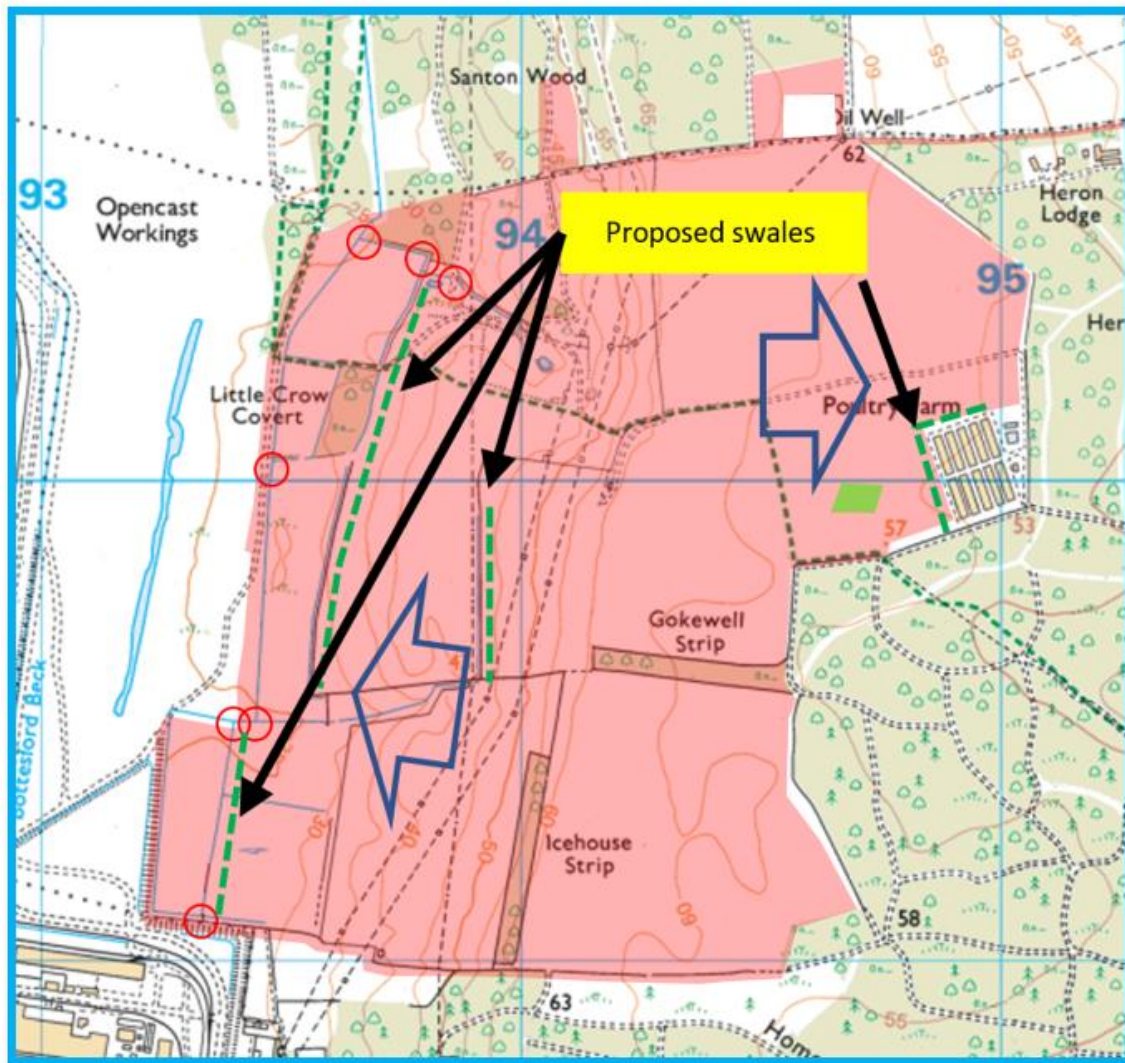

Fig 18 Plan showing Order Limits shaded to highlight existing watercourses. All structures such as solar panels and infrastructure will be more than 6m from illustrated watercourses, but fences will cross watercourses where appropriate at the locations represented by the red circles. Track and cable crossings are described later.

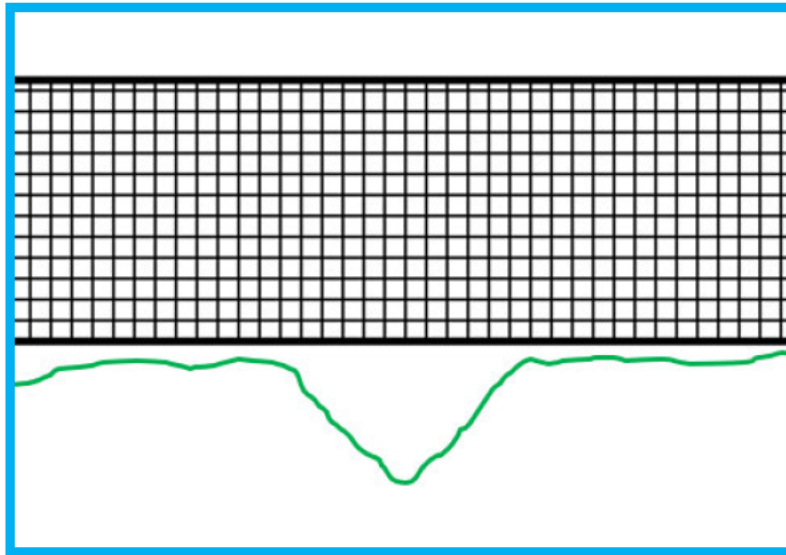

Fig 19 Indicative crossing of ditch with open deer fences generally 100mm above the surface to allow wildlife movements to continue.

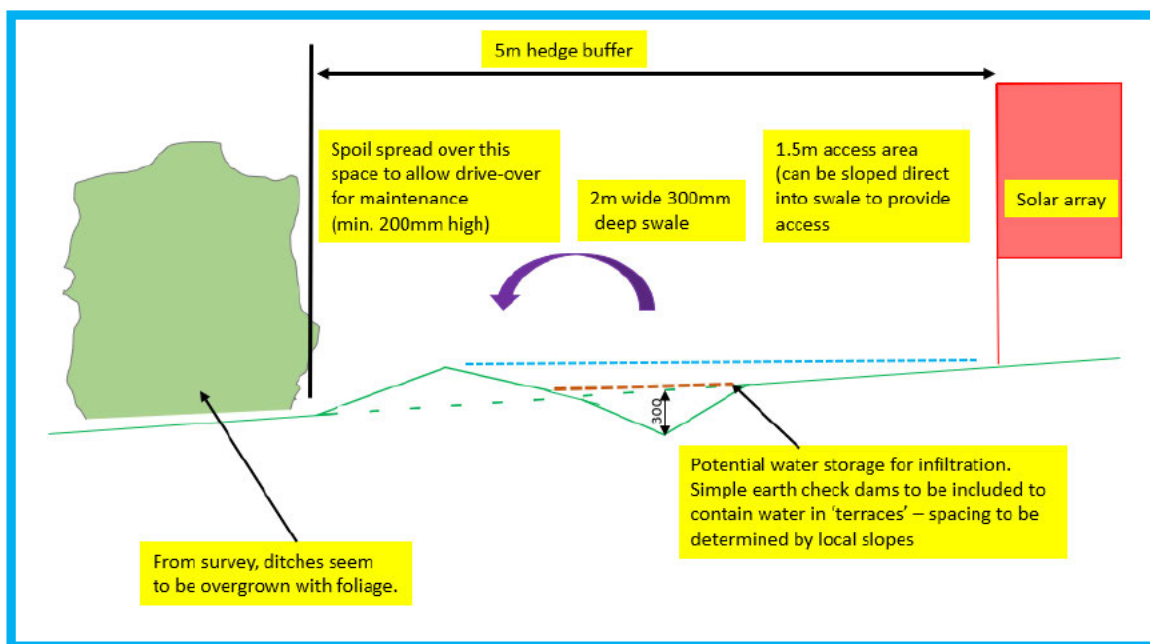

Fig 20 Typical swale formed with ridge and furrow technique and vegetated on completion. Ridge to be located on downhill side.

Transformer units etc will be positioned on legs with 300mm permeable gravel bed below to provide attenuation and infiltration into the underlying and adjacent soil. The substation compound will be similarly formed with a permeable gravel bed and the units founded through the bed.

The Battery Energy Storage System, which will be containerised and supported on legs, will also be formed over a permeable gravel bed to encourage infiltration and allow attenuation.

The Battery Energy Storage System is shown in Work No. 2A and an alternative location Work No. 2B (Figs 12a and 12b), and this method of managing rainwater applies equally to both locations.

The fields will no longer be applied with pesticides and fertilizers, thus the water quality entering the environment will be improved. The fields will no longer be left bare, with compacted 'tramlines' in the autumn and winter, thus improving infiltration and eliminating silt runoff. Bearing in mind the recent climate change assessment, the elimination of ploughing will also reduce the CO2 emissions.



Fig 21 Typical transformer unit on legs over permeable gravel bed.



Fig 22 Typical containerised batteries on legs with permeable gravel base below.

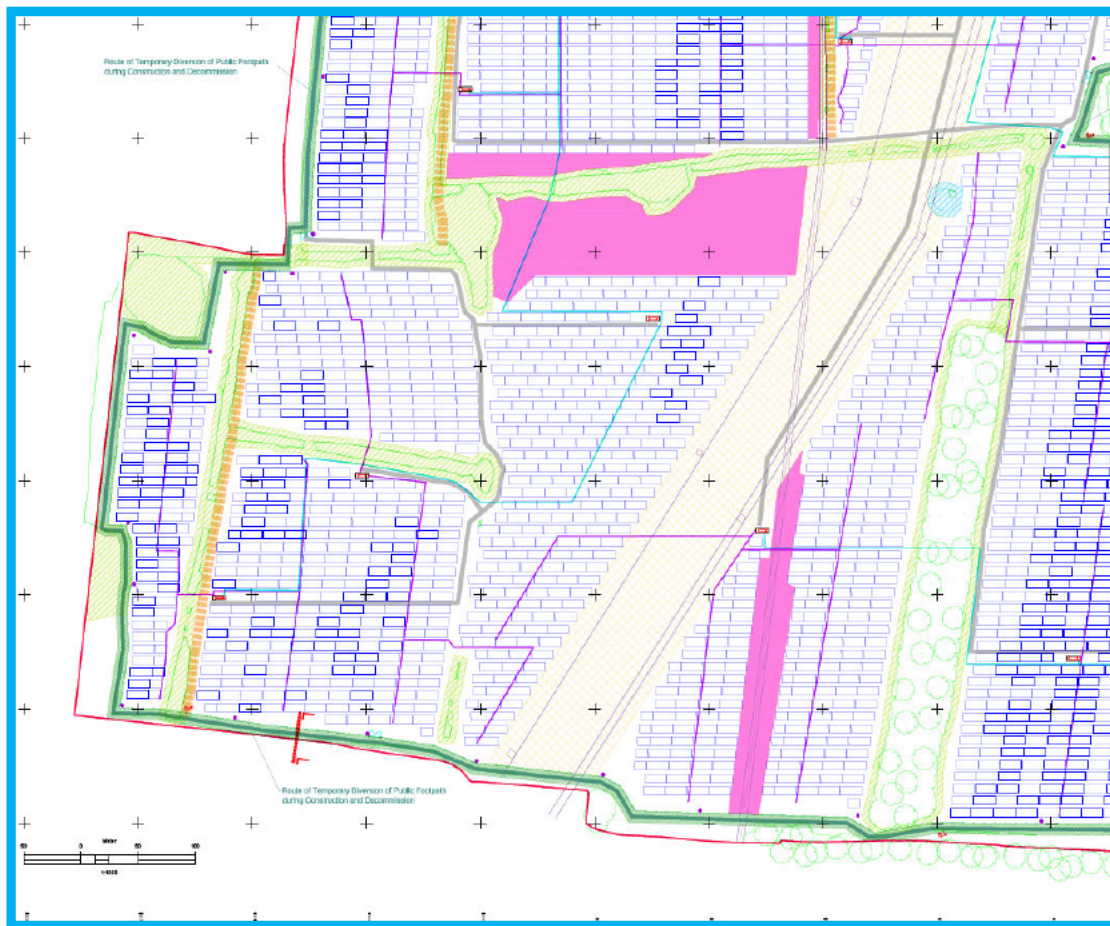

Fig 23 Typical expanded view showing retention of green corridors with vegetation and zones with watercourse and swales. New swales are shown in brown broken lines. The solar panels are 6m wide, giving a scale for the watercourse zones, which are in the order of 20m wide. Extract from Works Details – Key A3 – Sheet 3 of 7 (Document Ref 2.13 LC DRW).

8. Construction Process

To minimise damage to the soil structure within the Order Limits, the contractor should manage the work appropriate in the prevailing weather conditions and use appropriate machinery for the circumstances.

The Contractor will prepare a Construction Environment Management Plan (CEMP) based on the Outline Construction Environmental Management Plan (Document Ref 7.8 LC TA4.1), which will include precautions taken during the works. Existing watercourses will be protected by silt fences if there is a risk of silt runoff occurring during the works, dependent on weather and prevailing characteristics. Streaming during the works will be treated by filtering through geofabric or hay bales to prevent silt pollution of the receiving watercourses.

Machinery used within the solar farm should have low earth pressure tyres or tracks, such as is typical with farm machinery, to minimise compaction of the ground.

A delivery sequence by vehicles should be devised which minimises repeated journeys over the pasture to reduce rutting and damage to the pasture and soil structure.

On completion of the works the pasture should be restored using light farming machines and the soil prepared appropriately for seeding to encourage early growth, restoration of the soil structure and natural creation of meadow grass.

9. Land Drainage Consent

Land Drainage Consent (LDC) is normally required for works within 8m of the top of bank of a watercourse to ensure that the watercourse can be maintained and that out of bank flows can be managed.

There are no signs of out-of-bank flow at the Order Limits and the solar park will be well-managed as part of the routine maintenance.

Solar panels will be 6m or more from top of bank, to allow maintenance access; in some areas the shallow swales described above (and planting) will be included within this corridor.

Cables will be installed by 'no-dig' techniques, at least 1m below the bed of the ditch, to avoid potential nuisance to ditches.

Fences will cross the ditches 100mm above ground level; the fences will therefore not hinder flows in the watercourse.

Existing track crossings and associated culverts will be inspected, the culverts cleared if appropriate and maintenance undertaken to ensure the long term operation of the culverts with low maintenance.

One new track crossing is proposed across an existing ditch. The ditch crossing will include a large diameter culvert with soft invert and traditional sand/cement bag headwalls. Existing crossing locations will be investigated, and either retained or maintained as required.

Following consultations with the LLFA, a single LDC application form is attached in Appendix 1 with the details illustrating three potential locations where treatment might be required.

The Application Form is followed by the Consent Form, confirming acceptance of the proposals by the LLFA.

10. Management and Maintenance

The general solar park, watercourses, permeable tracks, permeable beds below units etc within the Order Limits will be maintained by the maintenance operator. The solar park will be routinely inspected every month or so, when weather is conducive to inspection and maintenance.

The solar park and in particular the watercourses should be inspected annually at the start of autumn and in late spring, and at other times if prevailing conditions suggest, and the following steps taken:

- Any blockages from branches, intense bramble growth etc. should be removed so that the swales can be readily inspected to confirm their clear operation.
- Any raised bed due to animal activity etc. which may hinder water flow should be removed to restore performance.
- Trees and shrubs should be removed before they can establish.
- Grass and wild flowers should be inspected and strimmed back from time to time.
- Bare earth areas should be inspected, prepared, seeded and protected to re-establish grass and wildflower growth as appropriate.
- If water ponds for prolonged periods inspections should be made and the bed treated to restore performance and aid infiltration.

The maintenance will be undertaken for the lifetime of the project in accordance with the landowner's Riparian responsibilities, and as explained in the pre-consultation response from the North Lincolnshire Council Drainage Officer.

11. Conclusions and Recommendations

INRG Solar (Little Crow) Ltd proposes the construction, operation, maintenance and decommissioning of a ground mounted solar park and associated Battery Energy Storage System with an intended design capacity of over 50MWp (megawatts peak) on land to the east of the British Steel site at Scunthorpe.

In summary:

- The Order Limits is entirely in Flood Zone 1 according to the EA Flood Map for Planning and appropriate development in this area.
- The local area to the Order Limits is not sensitive in terms of surface water flood risk.
- The Order Limits site is currently used for arable farming which causes compaction, reduces absorption of rainwater by the soil and increases soil runoff, particularly after harvesting.
- The soil within the Order Limits site is recorded as being free-draining.
- Swales are proposed to reduce the risk of runoff affecting the watercourse flows especially during construction, and uphill of the poultry farm boundary.
- The proposal will eliminate compaction, allow the soil and vegetation properties to improve and contain the rainfall within the Order Limits site, by infiltration into the ground.
- Runoff quality entering the environment will improve through ceasing the application of pesticides and fertilizers.
- Tracks will be formed in permeable construction.
- Track crossings of watercourses will incorporate large diameter culverts to reduce the risk of blockage.
- Transformer and Battery Energy Storage System units will be formed with permeable gravel beds to encourage infiltration.
- A management programme is described which ensures the soil and watercourse conditions will remain favourable for the lifetime of the development.

The proposal therefore brings significant benefit to the management of surface water, a reduction in runoff leaving the Order Limits site and the improvement in water quality entering the environment. The development does not increase the risk of flooding to the local area or lower in the catchment.

The Environment Agency, the Internal Drainage Board and North Lincolnshire Council (as Lead Local Flood Authority) have been consulted and there are no objections to the proposals. Furthermore, the LLFA has granted Land Drainage Consent for the 3 potential crossings.

The proposals comply with the National Planning Policy Framework (NPPF) and are therefore acceptable.

Appendix 1 Completed Land Drainage Consent Form and Plans,
followed by the Formal Consent

<u>NORTH LINCOLNSHIRE COUNCIL</u>	
<u>APPLICATION FOR WORKS IN NORTH LINCOLNSHIRE</u>	
LAND DRAINAGE ACT 1991 SECTION 23	
	
<u>DETAILS OF APPLICANT: -</u>	
APPLICANT/S NAME	<u>Mr David Dean</u>
COMPANY NAME	<u>INRG Solar (Little Crow) Ltd</u>
POSTAL ADDRESS	<u>17 Cavendish Square</u> <u>London</u> POSTCODE <u>W1G 0PH</u>
TELEPHONE NUMBER	<u>0333 800 2460</u>
EMAIL ADDRESS	<u>[REDACTED]</u>
OUT OF HOURS NUMBER	<u>[REDACTED]</u>
FAX NUMBER	<u>[REDACTED]</u>
SITE ADDRESS OR LOCATION OF PROPOSED WORKS	<u>Little Crow,</u> <u>Broughton</u> <u>Scunthorpe</u> <u>Lincolnshire</u> <u>DN16 1XA</u>



1. APPLICANTS INTEREST IN LAND

Developer

If you are not the owner of the land, please give his/her name and address and confirmation you have their permission to enter onto the land to complete the works.

2. AGENTS DETAILS

NAME	<u>CLIVE ONIONS LTD</u>	PROFESSION	<u>CHARTERED CIVIL ENGINEER</u>
ADDRESS	<u>2 STOWEY COTTAGES GOLDS CROSS PENSFORD BRISTOL</u>	CONTACT	<u>CLIVE ONIONS</u>
POSTCODE	<u>BS39 4DL</u>	TELEPHONE NO.	<u>01275 332216</u>
		FAX NO.	

3. LOCATION OF WORKS

NORTH LINCOLNSHIRE COUNCIL	<u>NORTH LINCOLNSHIRE COUNCIL</u>
NATIONAL GRID REFERENCE	<u>SE934101</u>
PARISH COUNCIL	<u>Broughton Town Council</u>

4. DESCRIPTION OF PROPOSED WORKS

Solar Farm and associated works

NUMBER OF STRUCTURES - | ONE

DETAILS OF THE PROPOSAL

Diameter, span, length and materials of construction of the culvert, bridge or structure. Inverts, soffit, crest levels:	<u>1 Track crossing of ditch with 1m culvert 2 Track crossing of culverted ditch – to be determined if changes required to culvert.</u>
Construction details of manholes, headwalls or other associated structures:	<u>Headwalls formed in traditional sand/cement bags</u>
Plan or Drawing Reference Nos.	<u>Attached</u>



5. BRIEF DETAILS OF ENVIRONMENTAL IMPACT OF WORKS, TOGETHER WITH ANY PROPOSALS FOR AMELIORATION AND/OR COMPENSATORY ENHANCEMENT

This Application is part of a Development Consent Order for a large solar farm, which must include the Land Drainage Consent Application Forms.

This includes a full suite of technical reports

A Construction Environment Management Plan (CEMP) will be prepared, which will cover the works associated with the culverted crossing of the track, to ensure no disturbance of flow or silt/contamination of the ditch

Environment Impact Assessment Report – Title /Date Nos.

6. STATE WHETHER WORKS ARE TO PERMANENT OR TEMPORARY

35 years

IF TEMPORARY, STATE DURATION REQUIRED

7. ASSOCIATED WORKS

ARE THE PROPOSED WORKS ASSOCIATED WITH THE MAKING OF A DISCHARGE OF TRADE EFFLUENT OR SURFACE WATER NO

ARE THE PROPOSED WORKS ASSOCIATED WITH THE ABSTRACTION OF WATER NO

**** DELETE AS APPLICABLE ****

8. WILL PLANNING APPROVAL BE REQUIRED?

Will Planning Permission be required?

If no, will Building Regulations be required?

Have either permissions been granted?

If yes please state the application no.

Approval date.

	<div style="border: 1px solid black; width: 100%; height: 15px; margin-bottom: 5px;"></div>
9. NAME OF PERSON OR ORGANISATION RESPONSIBLE FOR MAINTAINING THE STRUCTURE ON COMPLETION	
<p>INRG Solar (Little Crow) Ltd</p>	
<p><u>APPLICANT</u></p>	
NAME OF APPLICANT	<div style="border: 1px solid black; width: 80%; margin: 0 auto; padding: 2px;"> <u>INRG Solar (Little Crow) Ltd</u> </div>
POSTAL ADDRESS	<div style="border: 1px solid black; width: 80%; margin: 0 auto; padding: 10px;"> <p style="text-align: center;"><u>17 Cavendish Square</u> <u>London</u></p> <p style="text-align: center;">POSTCODE W1G 0PH</p> </div>
I/WE	<div style="border: 1px solid black; width: 80%; margin: 0 auto; padding: 2px;"> <u>INRG Solar (Little Crow) Ltd</u> </div>
<ol style="list-style-type: none"> 1. Apply for consent under the provisions of Section 23 of the Land Drainage Act 1991 to carry out works as described in this Application and on the attached plan(s). 2. Enclose a cheque for £50.00 to cover the cost of the application, made payable to North Lincolnshire Council. 3. Enclose one copy of the suitable plans sufficient to show clearly the location of the proposed works, together with one copy of plans and sections showing details of the proposed works to a scale appropriate to the nature of the works and any relevant calculations. 4. Confirm that I/We have the right to carry out the works and have obtained consent or approval as necessary. 5. Do not know of or suspect any other facts or information which would or might affect the granting of or conditions which might be imposed on the consent applied for. 6. Confirm that I/We will notify the Council of any future changes in the information given in this application which might be material to the continuation of this consent. 7. Confirm that all information given in this application and any questions which the Council may have about it is/will be true to the best of my/our knowledge, information and belief. 8. Undertake to submit a full and accurate application and accept that the period of two months specified in Section 23 of the Land Drainage Act 1991 for deciding the issue will not begin to run until the Council is satisfied that it has all the necessary information. 	
<p>Please return this form, together with your fee, to North Lincolnshire Council, Drainage Team, Highway Depot, 8-9 Billet Lane, DN15 9YH</p> <p>Note: You may submit proposals via pdf to the Drainage Team email address : LLFAdrainageteam@northlincs.gov.uk</p>	

SIGNED

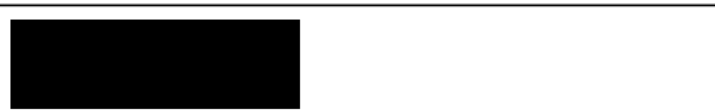

ON BEHALF OF

Clive Onions Ltd on behalf of INRG Solar (Little Crow) Ltd

DATED

12th August 2019

**ENVIRONMENTAL CONSIDERATIONS
FOR LAND DRAINAGE CONSENTS**

The Council is required to consider the environmental implications of all works in the North Lincolnshire administrative area which require its consent under the Land Drainage Act 1991 (as amended). The applicant is required to demonstrate the environmental impact of the proposals is negligible or can be mitigated against.

A number of species of animals and plants are protected under the Wildlife and Countryside Act 1981 (as amended). Water voles, otters, badgers and bats are known to inhabit watercourses and have varying degrees of protection under legislation. Other species may also be present in the area. The applicant is required to demonstrate that the proposed works are not likely to adversely impact on protected species and/or protected habitats. A surveyor opinion, by a suitably qualified individual, with mitigation proposals where appropriate will suffice in most cases.

Works which may affect sites of national or international wildlife importance require further measures to be taken. Such works may be remote from the site and the area of influence must be determined by the Board. The Council is required to obtain the assent of English Nature to such works, which is independent of any consent/assent the applicant may be required to obtain. In such cases where assent is required, the period required by the Board to determine an application is extended to 8 weeks for national sites and 16 weeks for international sites. The Council will endeavour to determine application as soon as possible but is dependant upon the responses from English Nature.

In determining applications it is necessary to consider other legislation including, but not exclusively: The Environment Act; the Habitats Regulations; the Water Framework Directive (WFD); the Countryside and Rights of Way Act; the Salmon and Freshwater Fisheries Act; the Eel Regulations.

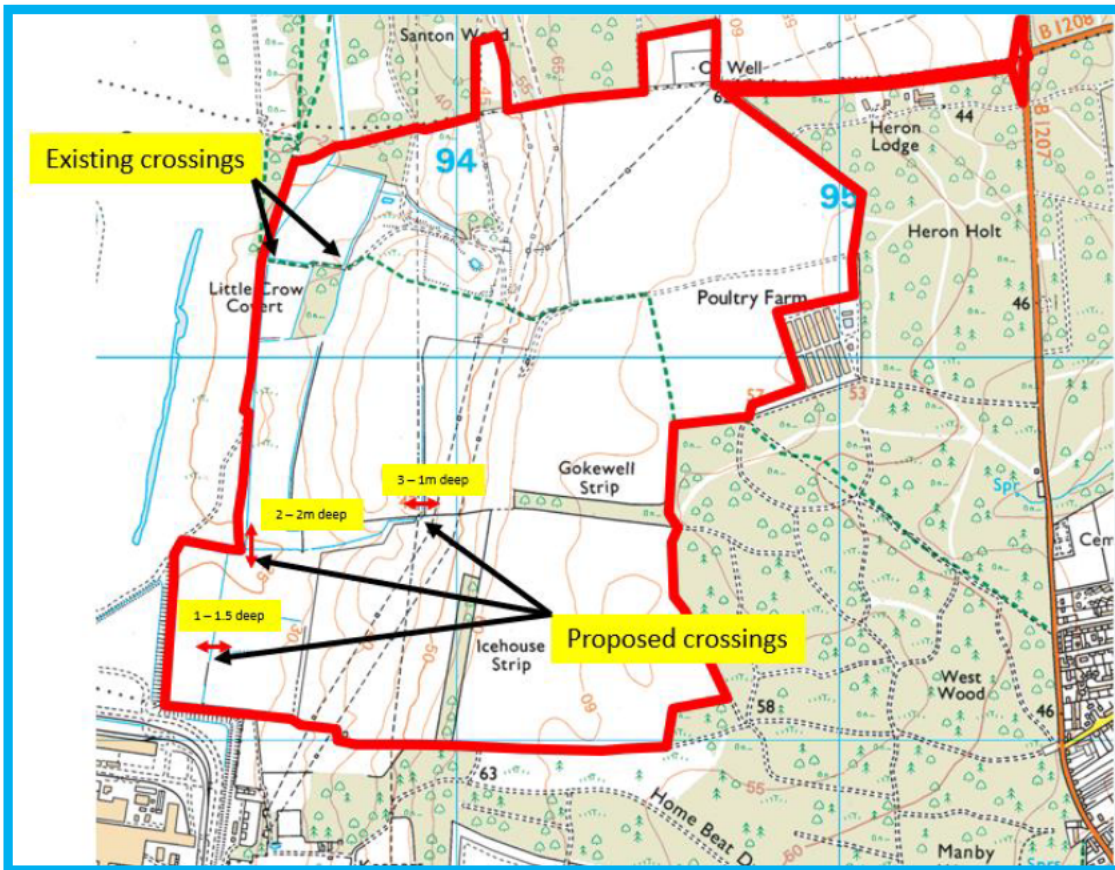

Location of track crossings.

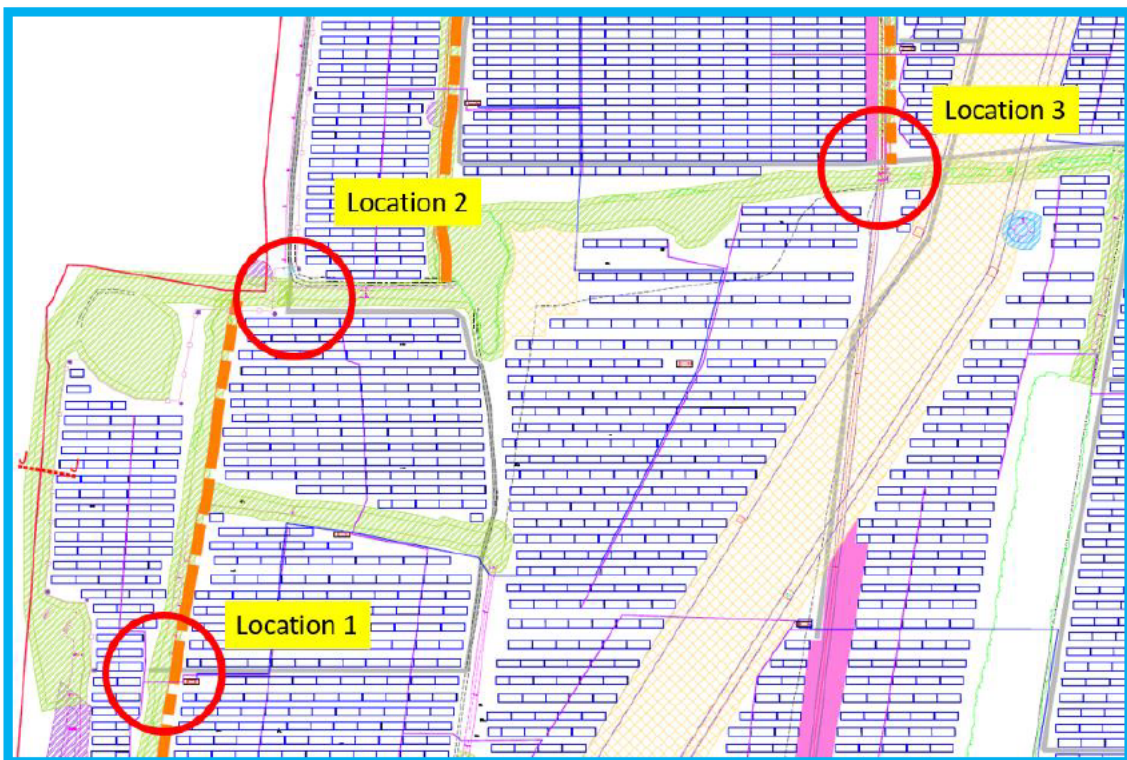

Location of track crossings on proposed layout.

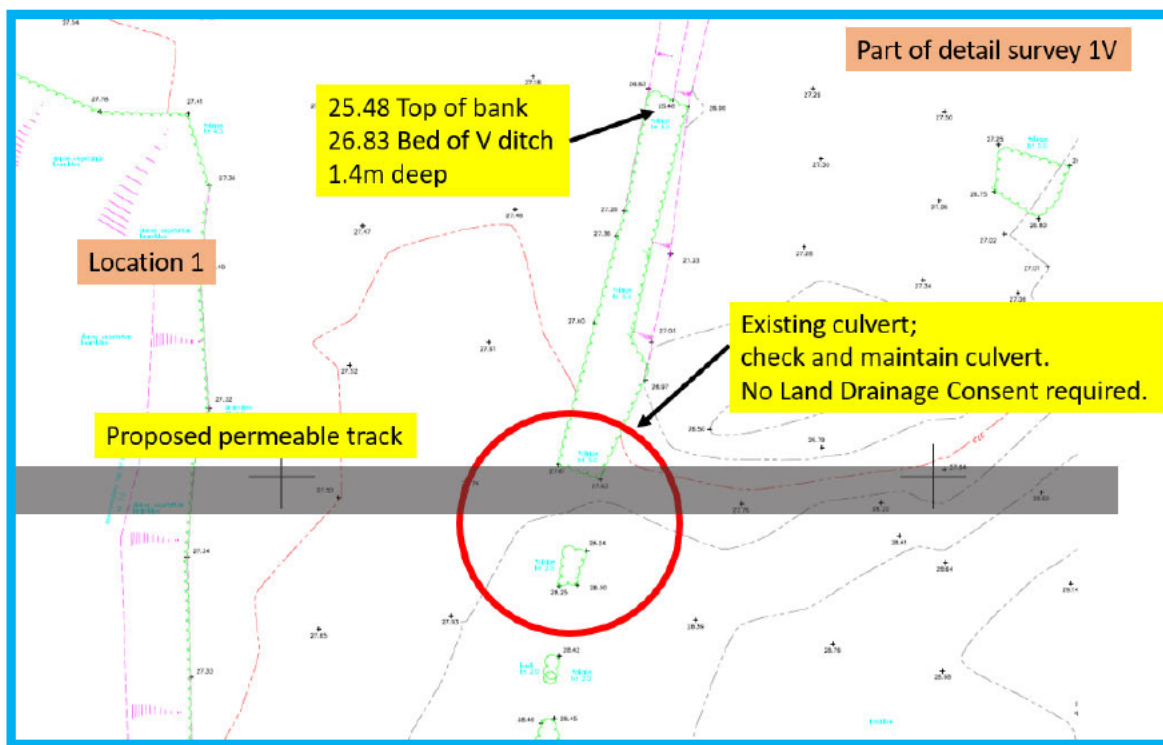

Location 1 No change to culvert – maintain existing - no Land Drainage Consent required.

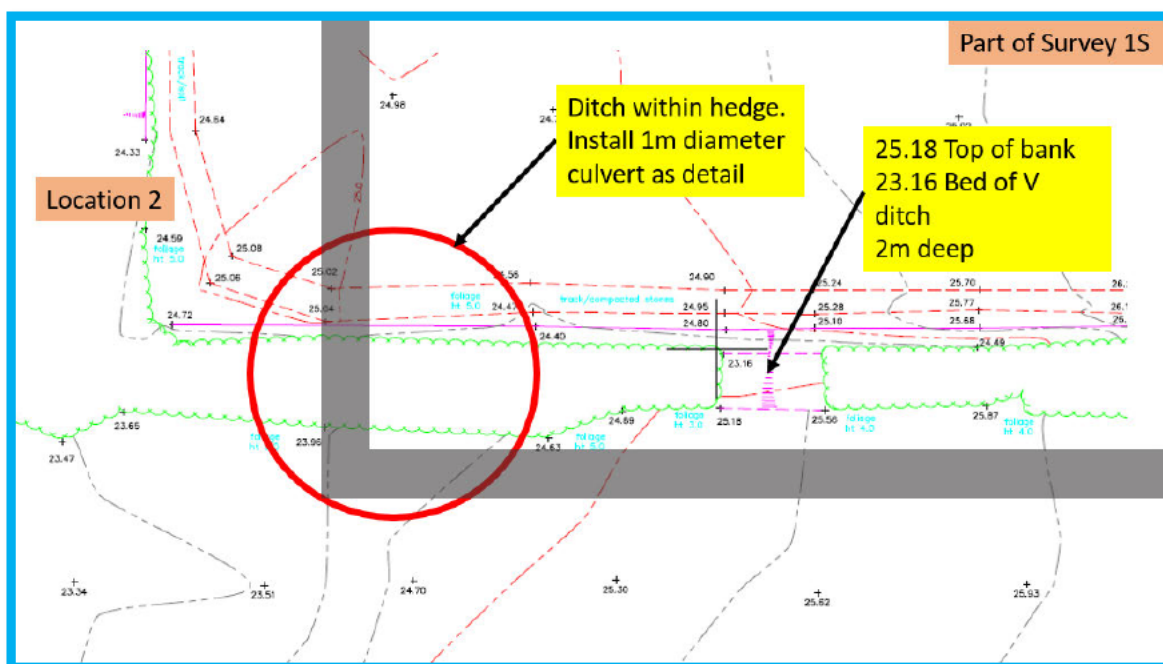

Location 2 Crossing of ditch and installation of culvert – Land Drainage Consent required.

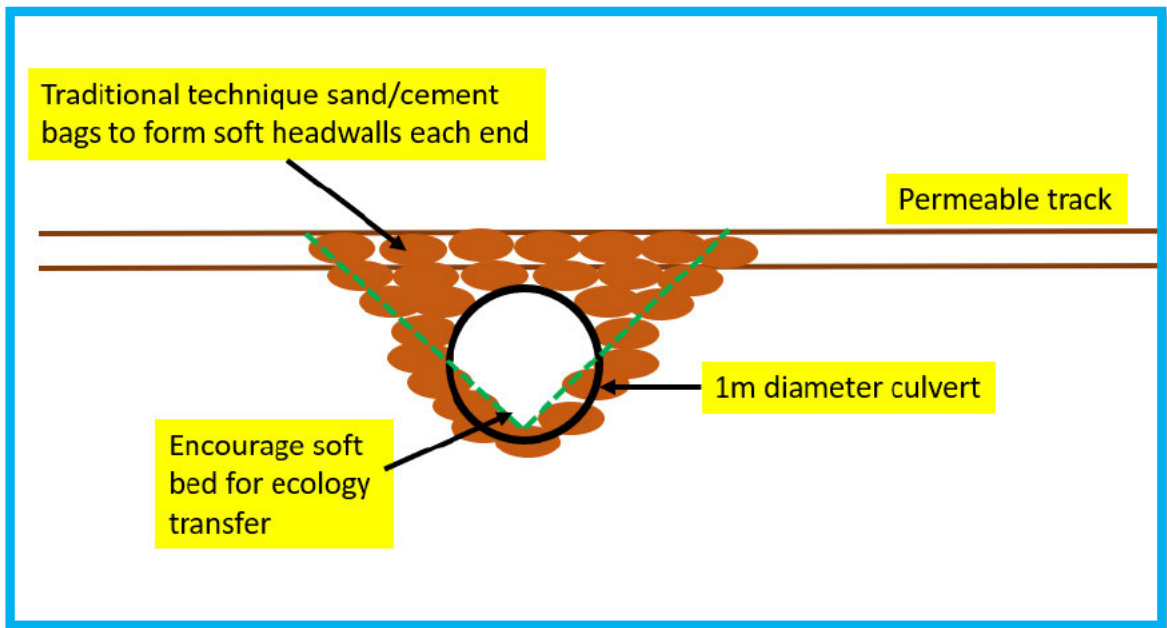

Location 2 Proposed detail of Culverted ditch.

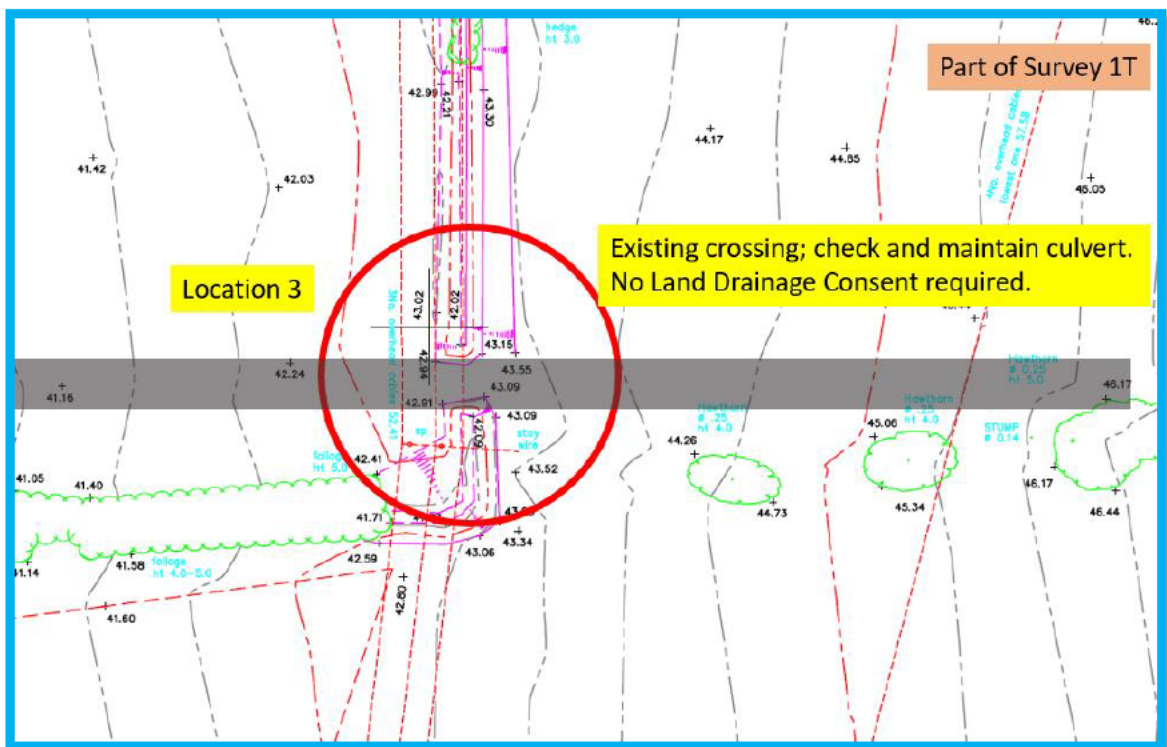

Location 3 Existing track crossing, no Land Drainage Consent required.

Ordinary Watercourse Land Drainage Consent



LLFA Ordinary Watercourse Consent

Land Drainage Act 1991

Name

INGR Solar (Little Crow) Ltd

**93 Leigh Rd
Eastleigh
Hants
SO50 9DQ**

Consent applying to

To bridge three watercourses at land west of Appleby Lane, Broughton

Consent Number

BD36_LCR_001

Effective from

23/10/19

Introduction

This Note does not form part of the Certificate of Authorisation.

Land Drainage Consents are required by virtue of the Land Drainage Act 1991. The following activities on an Ordinary (non-main) Watercourse require Local Authority Consent:

under Section 23 of the Land Drainage Act 1991

- the erection or alteration of any mill dam, weir or other like obstruction to the flow of any watercourse
- the erection or alteration of any culvert that would be likely to affect the flow of any watercourse

under Sections 17 and 20(2) of the Land Drainage Act 1991

- Any drainage works carried out by a local authority against flooding in connection with any watercourse

under Section 61F Land Drainage Act 1991 (Inserted by Schedule 22 Environment Act 1995)

- the operation of any drainage works, under the control of any Internal Drainage Board or local authority, so as to manage the level of water in a watercourse for the purposes of facilitating spray irrigation.

Note: Consent under the above legislation is required irrespective of whether the works are permanent or temporary.

Contraventions

In relation to Ordinary Watercourses, the authority can under Section 24 of the Land Drainage Act 1991 serve a legal notice requiring the person to abate the nuisance within a specified time. Failure to abide by such a notice can result in the North Lincolnshire Council carrying out the necessary remedial work and seeking to recover costs.

Land Drainage Act 1991

Land Drainage Consent

Control of works affecting watercourses and/or flood defences

Consent number BDR36_LCR_001

To: Clive Onions
2 Stowey Cottages
Golds Cross
Pensford
Bristol
BS39 4DL

As Agent to

INGR Solar (Little Crow) Ltd
93 Leigh Rd
Eastleigh
Hants
SO50 9DQ

North Lincolnshire Council in exercise of its powers under **Section 23** of the Land Drainage Act 1991 and subject to the conditions attached, hereby grants its consent in relation to the works or operations described in this Consent.

Watercourse: Ordinary watercourse

Location: Land west of Appleby Lane, Broughton

Map reference: 53°34'15.9"N 0°35'30.8"W

53°34'25.6"N 0°35'24.1"W

53°34'28.1"N 0°34'59.4"W

Description of works Install 1m dia culverts for watercourse crossings.

as detailed on plans and sections

- Drawings in folder BDG36_LCR_001 Little Crow

North Lincolnshire Council does not accept any responsibility for the design and construction of the works referred hereto and any liability for any loss or damage which may arise out of their design, construction, maintenance or use.

This Consent shall come into effect on

Date 23/10/19

Signed on behalf of North Lincolnshire Council



Sam Cross

Highway Development and Strategic Flood Risk Manager

North Lincolnshire Council

Conditions

This consent is granted with the following conditions:

General

This consent does not imply or grant planning consent for any works or access to any land not in the ownership of the applicant to carry out works.

The Council is to be notified when work on site is to commence and when the work is complete.

Timing

None

Temporary Works

No temporary works that may impede on the watercourse are permitted.

Site Specific

1. the level of the drain bed being retained at the same level;
2. the span and soffit level being as shown on the details provided;
3. flow along the watercourse during construction to be retained at all times;
4. during construction care must be exercised to ensure no pollutants or debris is able to enter the watercourse;
5. liability and responsibility for any third party losses during construction and in the future, considered to be as a consequence of the work included in the consented work, to be that of the riparian owners of the adjacent property for which the crossings are to serve;
6. the adjacent riparian land owner to be responsible for the future maintenance, repair and ultimate renewal of the crossing, all as or when required;

Other Information

None

Appendix 2 Environment Agency Response to Consultation



Mr Colin Virtue
Pegasus Planning Group
Equinox North Great Park Road
Bradley Stoke
Bristol
BS32 4QL

Our ref: AN/2019/128531/02-L01
Your ref: RM/P17-0718
Date: 09 May 2019

Dear Colin

Construction of a solar farm (126MW) - Development Consent Order, Planning Act 2008, Section 42 Consultation: Flood Risk Assessment and Drainage Strategy Little Crow Solar Farm, Broughton, Scunthorpe, DN16 1XP

I am writing with some additional comments to our Section 42 response of 1 February 2019, in relation to the Flood Risk and Drainage Strategy (FRADS) 16 November 2018 V3 by Clive Onions.

Clive has pointed out that our response did not mention the FRADS and has asked us to confirm whether we have any concerns with it.

We did not initially review the FRADS in detail as the site is in Flood Zone 1 (fluvial risk), while advising on surface water drainage in relation to flood risk is the responsibility of the lead local flood authority (LLFA) rather than the Environment Agency.

However, we have now looked again at the document and I can confirm that we have no objections to the proposals.

We do note there is somewhat limited evidence that the runoff will not cause any problems (e.g. infiltration test results) and that the greenfield runoff rate will be maintained or reduced. However, it is for the LLFA to satisfy themselves that the measures proposed in the FRA will adequately mitigate any potential increased risk to third parties.

Please note that the view expressed in this letter by the Environment Agency is a response to a pre-application enquiry only and does not represent our final view in relation to any future planning application made for this site. We reserve the right to change our position in relation to any such application.

Should you require any additional information, or wish to discuss these matters further, please do not hesitate to contact me on the number below.

Yours sincerely

Nicola Farr (for Annette Hewitson)
Sustainable Places - Planning Advisor



Cc Clive Onions, Consulting Civil Engineer: clive@cliveonions.com

Appendix 3 Pre-application Consultation Response with Comment from Drainage Officer representing the Lead Local Flood Authority (extracted from letter)

Enquiries to: Andrew Law
 Direct Dial: 01724 297490
 E-mail: andrew.law@northlincs.gov.uk

Our Ref: CON/2019/187

Date: 7 March 2019

Colin Virtue
 Executive Director
 Pegasus Group
 First Floor
 South Wing
 Equinox North
 Great Park Road
 Almondsbury
 Bristol
 BS32 4QL



www.northlincs.gov.uk

Peter Williams BSc, DMS, CErg, NEB, MCML AMIMEChE
 Director of Places
 Civic Centre
 Ashby Road
 Scunthorpe
 North Lincolnshire
 DN16 1AB

Dear Mr Virtue,

National Significant Infrastructure Project in the Energy Sector Informal Consultation with North Lincolnshire Council - Little Crow Solar Park, Scunthorpe

Thank you for your consultation notice under Section 48 of the Planning Act 2008.

I have taken the opportunity to review the Preliminary Environmental Impact Report (PEIR) and the technical appendices submitted to the authority. Technical consultees within the Council have raised matters which will hopefully advise the final production of the Environmental Statement and support you in making a robust submission to the Planning Inspectorate. I have enclosed these consultation responses for your information, please feel free to discuss these matters with the relevant consultee's and do not hesitate to contact me should you require any contact details for specific individuals. I would be grateful if you could keep me copied into any future correspondence with technical consultees so that I can project manage this scheme and collate formal responses to you in the future.

North Lincolnshire Council does not wish to raise any objection to the principle of the proposed scheme at this moment in time. At the examination stage North Lincolnshire Council will produce a Local Impact Report which will need to be agreed by local members at Planning Committee and as such we do reserve the right to raise concerns at a later stage following consideration of the application by committee members.

At this stage of pre-application consultation I would like to make the following observations:

Drainage

Having reviewed the Flood Risk Assessment and Drainage Strategy and taking advice from the council's drainage officers I can confirm that the scope and detail of the report is acceptable. Notwithstanding this, it is important that the developer ensures that all watercourses within the development site are maintained throughout the lifetime of the development in accordance with their riparian responsibilities.

Appendix 4 Shires Group Response to Consultation acting for Internal Drainage Board

From: [Jessica Taylor](#)
To: [Rachel Chen](#)
Subject: FW: Little Crow Solar Park, North Lincolnshire - Internal Drainage Board feedback
Date: 29 January 2019 16:49:38
Attachments: [image196066.png](#)
[image387314.png](#)

FYI

Jessica Taylor
Secretary to Colin Virtue

Pegasus Group

PLANNING | DESIGN | ENVIRONMENT | ECONOMICS

First Floor | South Wing | Equinox North | Great Park Road | Almondsbury | Bristol | BS32 4QL

T 01454 625945 | E jessica.taylor@pegasusgroup.co.uk

DD 01454 454085 | EXT 2003

Birmingham | Bracknell | Bristol | Cambridge | Cirencester | East Midlands | Leeds | Liverpool | London | Manchester | Peterborough



www.pegasusgroup.co.uk

Pegasus Group is the trading name of Pegasus Planning Group Ltd [072277000] registered in England and Wales. This email and any associated files, is intended for the exclusive use of the addressee only.

If you are not the intended recipient you should not use the contents nor disclose them to any other person.

If you have received this message in error please notify us immediately. We have updated our Privacy Statement in line with the GDPR; please click here to view it.



Please consider the environment before printing this email message.

From: Paul Jones <[REDACTED]>
Sent: 29 January 2019 16:34
To: info@littlecrowsolar.co.uk
Cc: [REDACTED]; Martin Spoor <[REDACTED]>; Ian Benn <[REDACTED]>; Naomi Wright <[REDACTED]>; Craig Benson <[REDACTED]>
Subject: Little Crow Solar Park, North Lincolnshire - Internal Drainage Board feedback

Dear Sirs,

The proposed site falls outside Internal Drainage Board Drainage Districts but surface water drainage from the site will eventually fall either to the west, into the Scunthorpe & Gainsborough Water Management Board (IDB) Drainage District, or east, into the Ancholme IDB Drainage District.

For both drainage routes surface water enters Main River which is the responsibility of the Environment Agency; to the west it will be directed to Bottesford Beck, to the east it will be directed through Broughton and Wressle and into Ella and Moor Beck.

Please contact the Environment Agency and North Lincolnshire Council with regards to any on site restrictions on surface water discharge from the site.

Kind regards,

For and on behalf of the Shire Group of Internal Drainage Boards,

Paul Jones BSc (Hons) MSc (Eng) GMICE
Engineer to the Board
 Lead Water Level Management Engineer

JBA Consulting, Epsom House, Chase Park, Redhouse Interchange, Doncaster, South Yorkshire, DN6 7FE. Telephone: +441302 337798
 WEM Framework Suppliers 2013-2019 and the Shire Group of IDBs is a member of the JBA group of companies.

Glossary

Above Ordnance Datum (AOD)	Height relative to the average sea level at Newlyn.
Catchment	The area contributing flow or runoff to a particular point on a watercourse.
Climate Change	Long term variations in global temperature and weather patterns both natural and as a result of human activity, primarily greenhouse gas emissions.
Culvert	Covered channel or pipe that conveys a watercourse below ground level.
Environment Agency (EA)	The official agency providing information on environmental issues, especially rivers, flooding from rivers and general pollution
Evapotranspiration	The process by which water is taken up by the roots of plants and conveyed up the plant providing nutrients and dispersing in the atmosphere by evaporation.
Flood Risk	An expression of the combination of the flood probability and the magnitude of the potential consequences of the flood event.
Flood Risk Assessment	A study to assess the risk of a site or area flooding, and to assess the impact that any changes or development in the site or area will have on flood risk. Usually used in the context of a site-specific Flood Risk Assessment (FRA). See Project Flood Risk Assessment.
Flood Zone	The Environment Agency (EA) has devised a set of flood zones for guidance by developers, councils and communities to explain the probability of river and sea flooding, ignoring the presence of flood defences to inform development planning.
Fluvial	Relating to a river or rivers
Fluvial Flooding	Flooding from a main river or other watercourse.
Infiltration	A soil characteristic determining or describing the percolation of water into the soil.
Internal Drainage Board	Body with powers and duties relating to ordinary watercourses within an Internal Drainage Board District.

Land Drainage	The process or a method of draining land.
Lead Local Flood Authority (LLFA)	The body responsible for surface water with particular interest in flood risk and drainage. It is usually part of the Local Council or Unitary Authority – in this case North Lincolnshire Council
Main River	A river which is not an ordinary watercourse – usually larger rivers or watercourses which are considered sensitive in terms of flood risk. The Environment Agency has particular interest in Main Rivers.
MW	A unit of power, equal to one million <u>watts</u> .
MWp	Megawatt of power.
Risk	Risk is a combination of the chance of a particular event, with the impact that the event would cause if it occurred. Risk therefore has two components – the chance (or probability) of an event occurring and the impact (or consequence) associated with that event. The consequence of an event may be either desirable or undesirable. Generally, however, the flood and coastal defence community is concerned with protecting society and hence a risk is typically concerned with the likelihood of an undesirable consequence and our ability to manage or prevent it.
Runoff	The flow of water from an area on the catchment surface, caused by rainfall.
Sustainable Drainage	Drainage which uses more natural features such as swales to manage rainwater runoff, and encourages natural processes such as evapotranspiration by vegetation and infiltration into the underlying soil. The contrast would be to simply discharge rainfall into a pipe at the rate at which it arrives, which often causes peaks of flow and pollution in the receiving watercourse
Swale	A low place in a tract of land, usually moister and often vegetated. A low-lying or depressed and often wet stretch of land. Swales are positive features and form part of a Sustainable Drainage system which can aid conveyance and/or infiltration

Reference List

- Streetmap website
- Google Earth website
- British Geological Survey Viewer website
- Cranfield University Soilsclapes Viewer website
- Environment Agency Flood Map for Planning
- Environment Agency Long Term Flood Risk Information/Mapping
- Environment Agency Surface Water Flood Risk Mapping
- Integrale, Phase 1 Ground Conditions Desk Study
- Lead Local Flood Authority

